

 **Superlux[®]**

2007 Product Catalog





2007



1945



1938



1935

Better Rhythm, Greater Idea Just Play It

The story started 60 years ago: Pan Chien-Yeu's father built China's first condenser microphone for his radio station after studying in Germany. Pan learned from his father and graduated with BSEE from Chau-Ton University. Pan has 45 years of electroacoustics professional design experience. It was 26 years ago that David Liu started to manufacture microphones. When David and Pan met in 1996, the best design and hands-on experience and the best quality mass production collaborated.

Together with all kinds of talents: mechanical, electrical, material, work-in-process, administration, computer science, RF engineering, visual communications, sales,... A team of determined people works around the clock, and after years of efforts, here we have created the products for the audio industry with the best sound performance from and the reasonable price - Superlux - products that let you play your music without overloading your budget. For OEM customer, Goang Fann provides from design to manufacturing services to meet the demands, from name brands to customized contracting installation projects.

True sound is the real value of Superlux products. Reasonable price is vital not only for budget limits, but also important for competitive business operations.

Industry standards are the guidelines to Superlux from design to products. Discipline to follow the standards sets a strong foundation. We value your music, your sound, and your business. When you choose Superlux products, you can just play your music. There are no burdens to your sound quality, no burdens to your financial considerations.

We love music, we enjoy listening, and we are proud to be part of music creation. More music, more fun.



David and Pan



SUPERLUX RANGE

PAGE 4

Wired Microphones



PAGE 28

Wireless Systems



PAGE 32

Measurement



PAGE 34

Accessories



PAGE 40

Cables



PAGE 42

Headphones



PAGE 44

Speakers



PAGE 48

Consumer



PAGE 52

Stands



Superlux continually research to improve products. The specifications could be changed without prior notice. For latest specifications, please visit www.superlux.com.tw or contact sales department.

PAGE 69 OEM/ODM projects

Microphones

Studio

Detail expressed sonic quality

4

Broadcast

On Air, Live Moment

8

Live Sound

Beats shake

10

Contractor

Flexible choices

24

Studio Microphones

Condenser studio microphones capture every detail. Touching the spirits.

Detail expressed Sonic quality

Precision crafted from design to production. Studio microphones demand the most detailed sonic nuance and sustained ultra high SPL as well.

Gold coating with vacuum evaporation process with $3\mu\text{m}$ thickness. Precision tensioned diaphragm, and no tolerance assembly with precision instrumented tuning provides years of stable performance.

High quality and ultra low noise pre-amplifier circuitry achieving wide frequency response from 20Hz to 20KHz, and 130dB dynamic range.

Linearity characteristics provide the freedom to the musicians and producers to create their works at their will.



Bigfoot Willie is designed for overweight microphones at extreme horizontal extension. Please go to P. 64 for detail.



CMH8G 8D

Vacuum Tube Condenser

Valve amplifier provides exceptional warm sound, and smooth sound textures. Suitable for creative applications.

G version provides dual diaphragm structure with remote 9 direction variations.

D version is dual diaphragm switch between omni and cardioid directivity.



CMH8C 8B 8A

Large Diaphragm, variable directivity

All purpose studio grade condenser microphone. 1" gold deposited diaphragm with skillful workmanship, for the most vivid sound.

H8C is the full version, comes with dual diaphragm for 3 switchable polar patterns.

H8B is single diaphragm with fix cardioid polar pattern.

H8A was designed for limit budget.



CMH8CH 8BH 8AH

Large Diaphragm, smile curve

Similar to the ensemble of CM-H8C/B/A. These 3 black versions kept the same variation. The difference is not only external appearances, but also internal design. Extended frequency performance in bass extension and HF enhancement. LED indicator will show if the phantom power source is working.

Pro Recording Studio
Classical Recording
Warm Vocals
Strings
Acoustic Guitar
Classical Piano
Brass
Woodwinds
Percussions

Pro Recording Studio
Live Recording
Vocals
Strings
Acoustic Guitar
Piano
Brass
Woodwinds
Percussions

Pro Recording Studio
Live Recording
Bright Vocals
Strings
Acoustic Guitar
Jazz Piano
Brass
Woodwinds
Percussions



- 1" gold coated 3µm thin film diaphragm
- Aluminium carrying case
- Champagne finish
- Specific power supplier included
- Specific cable from microphone to power supplier included.

- 1" gold coated 3µm thin film diaphragm
- Low noise transformer balanced output
- Champagne finish

- 1" gold coated 3µm thin film diaphragm
- A5 plastic carrying case including shock mount and foam windscreen.
- Black finish

CMH8D Omni, Cardioid 2 polar sw.
CMH8G Remote 9 polar sw.

CMH8A Cardioid, Internal Low Cut
CMH8B Cardioid, -10dB, Low Cut
CMH8C -10dB, Low Cut, 3 polar sw.

CMH8AH Cardioid, Internal Low Cut
CMH8BH Cardioid, -10dB, Low Cut
CMH8CH -10dB, Low Cut, 3 polar sw.

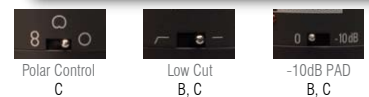
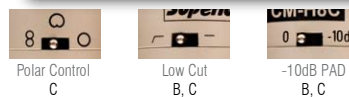

H8D matched with PS1 power supplier
H8G matched with PS3 power supplier
S65 windscreen foam included
HM7 shock mount included
HM8 stand mount included

Related Products

HM18AG Pop screen
HM48B, HM58B Table arm

SMKH8A Stereo kit, matched pair CMH8A
SMKH8B Stereo kit, matched pair CMH8B
SMKH8C Stereo kit, matched pair CMH8C

HM-8 stand mount included
A3 carrying case
YA-1 adapter

Related Products

PS2A Phantom power supplier
S65 Windscreen foam
HM7 Shock mount
HM18AG Pop screen
HM48B, HM58B Table arm

S65 windscreen foam
HM26A shock mount
HM8B stand mount included
YA-1 adapter

Related Products

PS2A Phantom power supplier
HM18AG Pop screen
HM48B, HM58B Table arm





NEW

S241

1/2" True Condenser

Precision 1/2" gold sputtered diaphragm. Based on years of condenser microphone experiences, this all new design included interchangeable cartridge.



WL

S125

1/2" True Condenser

Precision 1/2" gold sputtered diaphragm. Based on years of condenser microphone experiences, this all new design added with triple-layer wind screen for up-close vocal in recording studio as well as on the stage.



NEW

E524D

XY Stereo Electret

Coincident XY design, this all new design stereo microphone is a perfect tool for easy stereo recording setting, from studio, to live. Powered by internal battery or phantom power. For professional as well as amateur. Convenient blue light LED power indicator.



CMH8K

Electret Instrument

3 interchangeable capsules - cardioid, super cardioid, and omni. Multi purposes pencil type microphone. Easy to change for various applications. Excellent performance in electroacoustics characteristics and compact size.

Studio
Live Recording
Lead Vocal
Strings
Acoustic Guitar
Piano
Brass
Wood Winds
Percussions

Studio
Live Stage
Lead Vocal
Strings
Winds
Percussions

Live Recording
Studio Recording
Strings
Piano
Percussions
Winds

Live Recording
Vocal
Strings
Acoustic Guitar
Piano
Brass
Wood Winds
Percussion



- 1/2", 3µm thin film diaphragm
- Flat and wide response
- Modular capsule design
- -10 and -20dB PAD settings
- 2nd order 75Hz and 150Hz switchable low cut filters.
- Laser engraved serial numbering
- Precision automation manufacturing and SMD assembling.

- Built-in -10dB pad switch
- Built-in 3rd order (-18dB/oct) 150Hz low cut filter.
- Protective rubber cover on switch window to prevent accidental change.
- Wide and uniform response
- Shock mount capsule, very low handling noise.
- Conductive shielding, extremely low inherent noise and RF immunity.

- Phantom or battery
- Matched capsules
- Pre cut out foam for popular digital recorder in carrying case.

- Wide frequency response, emphasis on mid-high band
- High dynamic range, low distortion, transparent sound
- Detail texture suitable for mid high band instrument recording and live sound.

HM40 Shock mount
S09F Wind screen included
HM43 Pop screen included

Related Products

HM26B Shock mount
PS2A Power Supply

HM38S Clip Included
Mic Pouch Soft leather

Related Products

S40 Wind screen
PS2A Power Supply

Included Items:
HM38 mic clip
Mic cable 5M, XLR5F to 2 XLR3M
A4 Carrying Case
Mic pouch
DS01 Table Stand
S25 Wind screen
Battery 1.5V AA alkaline

Related Products

YA10 Camera mount adapter
HM40C On camera shock mount

SMKH8K Stereo pack, pair of CMH8KU and HM15
CMH8KHUO Includes all 3 capsules
CMH8KO Includes omni capsule
CMH8KH Includes super cardioid capsule
CMH8KU Includes cardioid capsule

HM32 Shock mount included
S08 Wind screen included

Related Products

HM26B Shock mount
PS2B Power Supply



AM100S24102A0 Omni Capsule
Omni directional capsule for S241 to interchange from cardioid to omni in recording application. Extremely flat response from 20Hz to 20KHz.



Broadcast Microphones

Precision tuned and crafted for broadcasting application. From indoor to outdoor.

On Air.

Live Moment

Capture every word...

Value your message...

Intelligibility with clear, noise free quality for studios and locations...

From news to productions.



Bigfoot Willie is designed for overweight microphones at extreme horizontal extension. Please go to P. 64 for detail.



R102 **NEW**

Classical Ribbon

Classical ribbon sonic texture. Suitable guitar as well as speech. Another typical application is stereo Blumlein recording due to its inherit figure-8 directivity. Also received well result on live stage music production for its rapid transient response over condenser counterpart

DJ, Speech
Guitar, E-Guitar
Bass section
Percussion



- Phantom power required.
- High sensitivity, wide dynamic range, low noise
- Low impedance output, low distortion.
- Pre-amplifier with integrated shielding to provide excellent performance.
- Figure-8 polar pattern, symmetrical front to back inside out.
- Easy to replace ribbon module.

R102 U-bracket
Cable Right angle cable included.
Related Products
PS2A Phantom power supplier
HM31 Shock mount
HM48B, HM58B Table arm



CMH8E

Large Condenser

Specialty design for broadcaster. Also suitable for instrument pickup. Internal pop screen reduced wind noise. Good for DAW and environmental immunity due to the close cell capsule structure.

DJ
Speech
Broadcast
Strings, winds instruments



- 1" diameter, gold deposited 3µm thin film diaphragm
- Low noise transformer output
- External 2 positions low cut filter
- Fix suspension mount and cable hanger

U bracket Attached
Related Products
PS2A Phantom power supplier
S65 Windscreen foam
HM48B, HM58B Table arm



PRA118

Shotgun Microphone

Highly directional pro shotgun electret microphones. Special designed for film and EFP productions. Also good for the-ater and SNG/ENG tasks.

Film, EFP
Theater live sound
SNG/ENG



- Exceptional off-axis suppression
- Very low coloration
- Flat on-axis response
- Long and short versions

PRA118L 54 cm, S15 foam
PRA118S 34 cm, S14 foam
HM37S, and carrying case included.
Related Products
PS2B Phantom power supplier
HM30S Shock mount
HM35 Shock mount
HM-35C Camera mount
YA10 Camera mount adapter



E523D **NEW**

XY Stereo Microphone

Matched pair capsules. For live recording, realism spacial capturing. 2 balanced outputs for pro audio/video system. Low-cut switch for reducing noise. Phantom or battery power.

Broadcast/TV
Pro recording
Outdoor production
Handheld digital recording



- Matched capsules
- Balanced outputs
- Phantom or battery power
- External low cut switch

Included Items:
HM38S mic clip
Mic cable 5M, XLR5F to 2 XLR3M
Mic pouch convenient carrying case
S50 Windscreen
Battery 1.5V alkaline AA

Related Products
HM40C On camera shock mount
YA10 Camera mount adapter



PRA318

Omni Interview

Omni dynamics are popular for SNG works. Aluminium alloy used for lowest handling load. En lengthen handle for easy reach and good for hand held operation. No proximity effect for best speech clarity

SNG/ENG
Interview
Speech Recording



- Frequency response designed for speech intelligibility
- No proximity effect
- Aluminium body, light and sturdy
- Special wind noise proof, good for outdoor

PRA318L Long shaft, 23 cm
PRA318S Short shaft, 18 cm

S07 Windscreen included
HM30 Shock mount included

Related Products
YA10 Camera mount adapter
DS01 Light weight table stand



PRA116B **NEW**

Shotgun Mic, Battery Power

Highly directional pro shotgun electret condenser microphones. Special designed for film and EFP productions. Also good for theater and SNG/ENG tasks. Battery for easy connection to amateur equipment.

Film, EFP
ENG, SNG
Theater live sound



- Exceptional off-axis suppression
- Very low coloration
- Flat on-axis response
- Battery power
- External low cut switch

Included Items:
HM38S, and carrying case
S14 Windscreen
Battery 6V, 4LR44, alkaline

Related Products
HM35 Shock mount
HM35C Camera mount
YA10 Camera mount adapter

LIVE SOUND





Vocal

When it comes to the mood

12

Wearing

Hands free

14

Instrument

Woods meets Brass...

16

Drum Sets

Beating together

20

Value Bundle

One for all

22

Vocal Microphones

Words for feeling, songs for touching. Ways to sing, always a match to your voice.

When it comes to the mood... Sing a Song



S125, studio grade vocal microphone under development. Gold sputtered diaphragm, condenser vocal microphone to the most demanding artists. All new for 2007, Detail on page 6.

A vocal microphone should be easy to hold with minimum handling noise. Sonic quality meets the singer's expectation to be a helpful tool to perform their music. Controlled directivity minimizes feedback, tailored response fits the popular curve that almost everyone is used to. There are choices of variations for artists to select the best match - in sound as well as in appearance.



WL
TOP248

Vocal Microphone

High performance Nd magnet and double diaphragm. Achieving high sensitivity and flat response. Excellent sonic quality to impress the audience. Rubber coating for comfort handling.

Lead Vocal
Speech
Music Instruments



TOP248S On/off switch included
HM38S Clip included



TOP258

Vocal or Instrument Mic

High performance ND magnet and double diaphragm. Achieving high sensitivity and flat response. Flat pop filter head to close-up miking. Rubber coating for comfort handling.

Winds
Strings
Percussion
Vocal



HM38S Clip included



WL
PRO248

Vocal Microphone

The Classical sound hand held vocal microphone. Strengthen grill and sturdy shaft for years of stable performance. Controlled directivity and tailored response suitable for vocal.

Lead Vocal
Speech
Music Instruments



PRO248S On/off switch included
HM38S Clip included



PRO258

Vocal or Instrument Mic

The Classical sound hand held vocal/instrument microphone. Strengthen grill and sturdy shaft for years of stable performance. Controlled directivity and tailored response suitable for vocal. Flat grill for close-up miking.

Winds
Strings
Percussion
Vocal



HM38S Clip included



WH5

Classical Vocal Microphone
Classical chrome gloss finish for special on stage decoration. 3 different response capsules for user to select his favorite one.

Lead Vocal
Speech
Broadcast DJ



D1 Table stand included

Special order



D108A

Vocal Microphone
Newly design for low profile in appearance, and great sonic performance due to precision tuned acoustic structure. On/off switch with locking plate. Exchangeable capsule simply by un-screw the cartridge.

Lead Vocal
Winds
Strings
Percussion



Mic pouch Soft carrying bag
HM38S Clip included



D109

Hi-Z Vocal Microphone
Hi impedance microphone for working with hi-impedance input equipments, such as guitar amplifiers.

Mic for guitar amp
Hi-Z inputs



Mic pouch Soft carrying bag
Cable 6M XLR3F to 1/4" phone plug cable included
HM38S Clip included
Related Products
CP838 Converter for low impedance, balanced output.



S125

1/2" True Condenser
Precision 1/2" gold sputtered diaphragm. Built-in 3rd order HPF and pad for stage vocal performance. Please refer **page 6** for detail.

Lead Vocal
Strings
Winds
Percussions



HM38S Clip Included
Mic Pouch Soft leather
Related Products
S40B1 Wind screen
PS2B Power Supply

WL

NEW



D103

Vocal Microphone
4 colors to choose make D103 the flexible choice for budget applications as well as semi-professional market. On/off switch and cable included.



Vocal
Speech
General purpose



FH12

Vocal Microphone
New style pop screen grill. Exchangeable capsule simply by un-screw the cartridge. No wire connection required. Excellent sonic performance.

Lead Vocal
Speech
General purpose



FH12 Without on/off switch
FH12S On/off switch included
HM38S Clip included



FI10

Instrument Microphone
New style pop screen grill. Exchangeable capsule simply by un-screw the cartridge. No wire connection required. Excellent sonic performance.

Vocal
Winds
Strings
Percussion



HM38S Clip included



PRO238C

Vocal Microphone
Handheld condenser vocal mic not only good for live sound performance, but also popular in DAW application.

Lead Vocal
Winds
Strings
DAW



HM38S Clip included

WL



PRAC1 C3 C5

Vocal Microphone
Spherical grill with on/off switch. Classical vocal sound and comfort holding. Multiple pack for convenient stage works.

Vocal
Speech
General purpose



PRAC1 Single Pack
PRAC3 Triple Pack
PRAC5 Five Pack
HM42A Clip included



PRAD1 D3 D5

Vocal Microphone
Flat front grill without on/off switch. Designed for vocal and for instrument pick up as well.

Vocal
Speech
General purpose



PRAD1 Single Pack
PRAD3 Triple Pack
PRAD5 Five Pack
HM42A Clip included



ECO88

Vocal Microphone
Zinc alloy body with Nd magnet capsule makes this economic design microphone to be the best choice even compared with pricier competitors. Built-in on/off switch.

Vocal
Speech
General purpose



Mic Pouch Soft carrying case
HM9A Clip included

6 pack



ECO A1 A2 A3

Vocal Microphone
Zinc alloy body with slider ball on-off switch makes this economic design microphone to be the best choice even compared with pricier competitors.

Vocal
Speech
General purpose



ECO A1 Single pack
ECO A2 Double pack
ECO A3 Triple pack
HM9A Clip included

Value Bundle Item

Wearing Microphones

Nature way to perform, for guitarist, drummer, and dancing singers...

Always helpful...

Hands Free

You always need your hands somewhere else than holding the microphone. Other than a microphone on a stand, wearing the microphone is a brilliant way to dance freely on the stage and still keep the microphone at a constant position to your mouth. Wearing microphones always provides a model for wireless belt-pack transmitters.





PRA20 **WL**

Dynamic Headworn
Dynamic microphone specially design for close-up miking as headworn always keep the microphone at a very short distance. Especially suitable for speech and to work without phantom power.

Speech
Presenter
Conference



PRA20TQG TA4F for wireless
PRA20XLR XLR3M plug
Included Items:
S11 Wind screen



PRA30 **WL**

Condenser Headworn
Condenser microphone specially design for close-up miking as headworn always keep the microphone at a very short distance. Especially suitable for singing and music production.

Lead Vocal
Guitar player
Dancer
Drummer



PRA30TQG TA4F for wireless
PRA30XLR PS418S included
PRA30DXLR PS418D included
Included Items:
S11 Wind screen
Battery 1.5V alkaline AA (DXLR)



E10A **WL** **NEW**

Condenser Headworn
Condenser microphone specially design for close-up miking as headworn always keep the microphone at a very short distance. New design to organize the cable neatly.

Vocal
Guitar player
Dancer
Drummer



E10ATQG TA4F for wireless
E10AXLR PS418S included
E10ADXLR PS418D included
Beige Skin color version
Included Items:
S23 Wind screen
Battery 1.5V alkaline AA (DXLR)



E10B **WL** **NEW**

Figure 8 Miniature
Figure 8 condenser microphone for hidden recording. Good surrounding sound rejection. High gain before feedback for live stage.

Speech
Drama
Gym Instructor



E10BTQG TA4F for wireless
E10BXLR PS418S included
E10BDXLR PS418D included
Beige Skin color version
Included Items:
S23 Wind screen
Battery 1.5V alkaline AA (DXLR)



E12A **WL**

Omni Sub Miniature
Sub miniature condenser microphone with minimized appearance. Specially designed frequency response for vivid sound performance.

TV broadcasting
Speech
General purpose



E12ATQG TA4F for wireless
E12AXLR PS418S included
E12ADXLR PS418D included
Included Items:
S53 Wind screen
Tie clip, clip base,
Battery 1.5V AA batteries (DXLR)



WO518 **WL**

Omni Miniature
Omni condenser microphone for hidden recording. Picks up surrounding sound easily. Suitable for recording without live sound.

TV broadcasting
Speech
General purpose



WO518TQG TA4F for wireless
WO518XLR PS418S included
WO518DXLR PS418D included
Included Items:
S12 HF boost wind screen
S13 Wind screen
Tie clip
Battery 1.5V alkaline AA (DXLR)



WU518 **WL**

Cardioid Miniature
Cardioid condenser microphone for hidden miking. Suitable for live sound application.

TV broadcasting
Speech
General purpose



WU518TQG TA4F for wireless
WU518XLR PS418S included
WU518DXLR PS418D included
Included Items:
S12 HF boost wind screen
S13 Wind screen
Tie clip
Battery 1.5V alkaline AA (DXLR)

Instrument Microphone

A selection of various microphones is important for various instruments.

Melody mix

Wood vs. Brass

Soft wood winds meets strong brass, elegant strings meets pounding percussions. Instrument microphones face various styles and levels, and capture vivid sound to storm strength. Transform the sound faithfully into electronic signal.



WL

PRA383

Clip-On Gooseneck Mic

Easy to clip onto various instruments and simple to adjust by bending the short gooseneck for the sweet spot. A good choice for wireless belt-pack.

Strings
Winds
Percussions



WL

E101

Guitar Microphone

A tie clip style miniature microphone added with a guitar clip and special tuning for acoustic guitar. A suitable choice for wireless acoustic guitar setup.

Guitar



NEW Hi-Z

D112

Harmonica Mic

Blues harmonica microphone, curves meets the holding hands when playing. Level knob for player to adjust suitable sound level. Permanent attached cable. Hi-Z matched with popular guitar amplifier.

Harmonica



PRO218A

Kick Drum Microphone

Specially designed for kick drum for its 174dB SPL maximum level and tuned frequency response. Also suitable for bass section instruments.

Kick Drum
Bass section



WB383 TA4F for wireless
PRA383XLR PS418S included
PRA383DXLR PS418D included
Battery 1.5V alkaline AA (DXLR) included

E101TQG TA4F for wireless
E101DXLR PS418D included
Tie clip Included
Guitar clip Included
S06 Wind screen included
Battery 1.5V alkaline AA (DXLR)

Related Products
CP838 Converter for low impedance, balanced output.

HM30B Mic clip included
Mic pouch Soft carrying bag (SGL pack)
DRKB5C2MKII includes 1 PRO218A



PRO228A

Tom-tom Microphone

Specially designed for tom-tom with permanent attached microphone clip. Also suitable for winds. 150dB SPL ability.

Tom-Tom
Snare
Percussion
Winds



PRO268B

Instrument Microphone

Back electret condenser microphone for drum set overhead. Also suitable for mid to high frequency instruments. Inter-changeable capsule design.

Drum set overhead
Strings
Winds
Guitar



PRA288A

Snare Noise Microphone

Specially designed for snare noise pick-up. Tuned frequency response with roll off low end, and slightly roll off hi end. Good for mid-high frequency biased instrument.

Snare noise
Oboe
Surna



Value Bundle Item

D10B

NEW

Instrument Microphone

Specially designed for mid-high frequency band instruments. High SPL capability. Humbucking coil to reduce interference by other equipment.

Strings
Winds
Percussion
Acoustic Guitar, Guitar Amp



Mic pouch Soft carrying bag (SGL pack)
DRKB5C2MKII includes 3 PRO-228A

HM30S Mic clip included
S20Wind screen included (SGL pack)
Mic pouch Soft carrying bag (SGL pack)
DRKB5C2MKII includes 2 PRO-268B

HM10B Mic clip included
Mic pouch Soft carrying bag (SGL pack)
DRKB5C2MKII includes 1 PRA-288A

HM38S Mic clip included
Mic pouch Soft carrying bag
Related Products
HM54 Shock mount
HM25 Drum clamp



Value Bundle Item

E124D

NEW

Electret Instrument

High sensitivity, flat frequency response electret condenser microphone. Specially design for instrument miking application. Phantom and battery dual power allow E124 to be used in pro-audio as well as amateur systems.

Acoustic Guitar
Strings
Piano
Percussion



E100

NEW

Kick drum Boundary Mic

Low profile boundary mic with built-in electronics. Easily place on a pillow or other surface in a kick drum for excellent attack and bass punch. Very high SPL ability and lower sensitivity to match Kick drum without overloading mic amplifier in a mixer. 1.5M permanent attached cable.

Kick drum
High SPL bass section



E102

NEW

Instrument Microphone

New small diaphragm electret condenser. Suitable for high frequency signal pickup. Especially for overhead in a drum set, or unobstructed settings for most music instruments.

Percussion
Strings
Brass
Piano



FK2

Kick Drum Microphone

Specially designed for kick drum with high SPL ability and tuned frequency response. Also suitable for bass instrument pick-up. Rich punch and good attack. Permanent attached mic clip.

Kick Drum
Bass section



Included Items:
HM38S Mic clip
Mic pouch Soft carrying bag
Mic Cable Choices of 6-meter, XLR3F to Ø6.3 plug or XLR3F to XLR3M cable
Battery 1.5V alkaline AA
S09 Wind screen

Related Products

HM32S Shock mount
HM43 Pop filter



Mic pouch Soft carrying bag (SGL pack)
DRK681 includes 1 E100



Included Item:
S27 Wind screen
HM10B Mic clip
Mic pouch Soft carrying bag (SGL pack)
DRKK5C2 includes 2 E102



Mic pouch Soft carrying bag (SGL pack)
DRKF5H3 includes 1 FK2



PRA628

Instrument Microphone

General purpose instrument dynamic microphone. Flat pop screen for up-close miking. Suitable for guitars, strings, and winds.

Guitar Amp
Bass Amp
Keyboard Amp
Speaker



PRA638

Instrument Microphone

General purpose instrument condenser microphone. Flat pop screen for up-close miking. Suitable for guitars, strings, and winds.

Acoustic Guitar
Winds
Strings
Piano



PRA218A

Kick Drum Microphone

Hi SPL capability, specially designed for kick drum. Also suitable for other bass band or high SPL instruments. Permanent attached mic clip.

Kick, drum Set
Bass instrument



PRA218B

Kick Drum Microphone

Hi SPL capability, tuned frequency response, specially designed for kick drum. Also suitable for other bass band or high SPL instruments.

Kick, drum Set
Bass instrument



Included Items:
HM10B Mic clip
HM12DA Gooseneck clip
Mic pouch Soft carrying bag (SGL pack)



Included Items:
HM10B Mic clip
HM12DA Gooseneck clip
Mic pouch Soft carrying bag (SGL pack)



Mic pouch Soft carrying bag (SGL pack)
DRKA3C2 includes 1 PRA218A
DRKA5C2 includes 1 PRA218A



HM30B Mic clip included.
Mic pouch Soft carrying bag (SGL pack)
DRKK5C2 includes 1 PRA218B



FT4

Tom-Tom Microphone

Specially designed for tom-tom with permanent attached microphone clip. Also suitable for winds.

Tom-Tom
Winds



FS6

Snare Drum Microphone

Specially designed for snare drum with permanent attached microphone clip. Also suitable for winds.

Snare Drum
Wood Winds
Brass



HO8

Overhead/Vocal Mic

19mm back electret condenser microphone, suitable for wide range applications. From drum set overhead to project studio, covering vocal, guitar, strings, and winds.

Overhead, Drum Set
Vocal
Guitar
Strings and Winds



HI10

Hi-Hat Microphone

Integrated electronics back electret condenser small diaphragm microphone, suitable for high frequency instruments. From hi-hat in drum set, guitar, to strings.

Overhead, hi-hat
Guitar
Strings



E109

NEW

Instrument Mic

Integrated electronics back electret condenser microphone with interchangeable capsules. Suitable for high frequency instruments. From overheads, hi-hat, to strings.

Overhead, hi-hat
Guitar
Strings
Winds



Mic pouch Soft carrying bag (SGL pack)
DRKF5H3 includes 3 FT4



Mic pouch Soft carrying bag (SGL pack)
DRKF5H3 includes 1 FS6



Mic pouch Soft carrying bag (SGL pack)
DRKF5H3 includes 2 HO-8



HM10B Mic clip included
S20 Wind screen included
Mic pouch Soft carrying bag (SGL pack)
DRKF5H3 includes 1 HI-10



HM10S Mic clip included
S20 Wind screen included
Mic pouch Soft carrying bag (SGL pack)
DR-681 includes 3 E-109



PRA228A

Instrument Microphone

Tuned response dynamic suitable for tom-tom, floor tom or snare. Also suitable for guitar or similar instruments. Permanent attached mic clip.

Tom-tom, drum set
Guitar
Strings



PRA268A

Instrument Microphone

Back electret condenser instrument microphone for drum set overhead or hi-hat. Also suitable for strings and wood winds. Permanent attached mic clip.

Overhead, drum set
Winds
Strings



Mic pouch Soft carrying bag (SGL pack)
DRKA3C2 includes 2 PRA228A
DRKA5C2 includes 4 PRA268A



S09 Wind screen (SGL pack)
Mic pouch Soft carrying bag (SGL pack)
DRKA3C2 includes 2 PRA268A
DRKA5C2 includes 2 PRA268A



Drum Sets

Research brings out drum sets for various demands. From complex package to a simplified set.

Beating together

Pack together

Pack 'n' go, drum set microphones are designed for convenience and best results for the sound man or drummer. A sturdy reinforced plastic carrying case or aluminium carrying case packed from basic to complete set of microphones, clips, and K5C2 even includes cables. Not only the sound quality is excellent, the value is also a budget saver.



DRK681

NEW

8 x Condenser Mic Set

This full condenser drum set comprises with 4 x Superlux PRA-383XLR covering Tom-tom and snare, new E100 kick mic, and 3 new E109 condenser mics for overheads and hi-hat. These high quality condenser microphones are also good for strings, winds and percussion.

Recording Studio
Live Stage
Strings, Winds
Percussion



DRKB5C2MKII

Giant 7 Mic Set

Best choice for live sound as well as studio. Comprised with 1 PRO-218A for kick, 3 PRO-228A for tom-tom, and snare, 1 PRA-288A for snare noise, and 2 PRO-268B condenser for overhead. These high quality mics are also suitable for other instrument pick-up. Packed in a convenient plastic carrying case.

Recording Studio
Live Stage
Percussion



DRKF5H3

Super 8 Mic Set

8 mic set, with 2 x HO-8 for overhead. 1 x FK-2 for kick, 3 x FT-4 for tom-tom, 1 x FS-6 for snare and 1 x HI-10 for hi-hat. Packed in a convenient plastic carrying case. Not only for drum set, but also a good choice for other instruments.

Live Stage
Recording Studio
Percussion



Aluminium carrying case
1 E100
4 PRA383XLR
3 E109
3 HM10S mic clips
3 S20 Wind screens

Plastic carrying case
1 x PRO218A
3 x PRO228A
2 x PRO268B
1 x PRA288A
3 x HM10S mic clips
2 x S20 foam wind screen

Plastic carrying case
1 x FK2
3 x FT4
1 x FS6
2 x HO8
1 x HI10
1 x HM10B mic clip included.

Related Products
HM12A Drum clamps. Refer P. 38

Related Products
HM12A Drum clamps. Refer P. 38



DRKK5C2

NEW

Complete 7 Mic Set

7 mic set, comprised with 3 tom-tom mics, 1 snare mic, (with permanent clips) 1 PRA-218B for kick, and 2 E102 condenser for overhead. Packed in a aluminium case, with 4 x HM-12A drum clamps and 8 microphone cables.

Live Stage
Project Studio
Percussion



Aluminium carrying case
1 x PRA218B
3 x TOM-TOM Mic
1 x Snare mic
2 x E102
HM-30B for PRA-218B
4 x HM12A drum clamps
8 x Cables XLR to XLR



DRKA3C2

Compact 5 Mic Set

Designed for live stage and practice room. Simple, yet complete with 1 PRA-218A for kick, 2 x PRA-228A for tom-tom, and 2 PRA-268A condenser for overhead. All microphones included permanent attached mic clip.

Live Stage
Practice Room



Plastic carrying case
1 x PRA218A
2 x PRA228A
2 x PRA268A
Related Products
HM12A Drum clamps. Refer P. 38



DRKA5C2

Extended 7 Mic Set

Designed for live stage and practice room. Including 1 PRA-218A for kick, 4 PRA-228A for tom-tom and snare, and 2 PRA-268A condenser for overhead. All microphones included permanent attached mic clip.

Live Stage
Luxury Practice Room



Plastic carrying case
1 x PRA218A
4 x PRA228A
2 x PRA268A
Related Products
HM12A Drum clamps. Refer P. 38

Value Bundle

Ready solutions for various tasks. Bundle microphone, cable, and stand within a convenient carrying bag. Take it and do it.

One for all

Your needs, our solutions



We need a mic stands to use a microphone. Wired microphone certainly shall be connected with microphone cable. Our value bundles answer the demands with singer package, instrument player package, and light weight condenser package.



MSKA

Singer Pack

Boom stand MS108, vocal microphone ECO-A, HM9A mic clip, soft mic pouch, 6-meter mic cable, top open carrying bag that holds all.

Singer
Teacher
Presenter



- 1 x ECOA
- 1 x 6M XLR-XLR mic cable¹, or XLR-¼" phone plug²
- 1 x Mic pouch
- 1 x HM9A mic clip
- 1 x MS108 stand
- 1 x Top open carrying bag



MSK10B

Instrument Mic Set

Instrument microphone D-10B incorporating humbucking coil bundle with MS108 boom stand. Package includes cable, clip, and carrying bag.

Guitar player
String player
Winds player
Percussion
Vocal



- 1 x D10B
- 1 x 6M XLR-XLR mic cable¹, or XLR-¼" phone plug²
- 1 x Mic pouch
- 1 x HM38S mic clip
- 1 x MS108 stand
- 1 x Top open carrying bag

MSK124

Condenser Mic Pack

Excellent instrument/vocal microphone packed with light weight aluminium traveller stand MS-128. This package is the answer to traveller acoustic instrument musicians.

Guitar player
String player
Winds player



- 1 x E124D
- 1 x 1.5V AA alkaline
- 1 x 6M XLR-XLR mic cable¹, or XLR-¼" phone plug²
- 1 x Mic pouch
- 1 x HM38S mic clip
- 1 x S09 wind screen
- 1 x MS128 stand
- 1 x Side open carrying bag



¹ MSK-AX, MSK-10BX, MSK-124X
² MSK-AP, MSK-10BP, MSK-124P

Contractor Series

Elegant appearance, easy to install, long term supplying stability, this range of products meets your needs.

Easy Reach

Flexible choices

Easy to reach in use, in installation, and in buying. Superlux contractor series brings you gooseneck microphones with dynamic or condenser capsules. Various lengths, various type of microphones are here for you to choose from.



GM13D 34 cm length, TA3F to XLR3M
GM13G 34 cm length, XLR3F to XLR3M

E321 gooseneck, Inter-changeable cartridges



HM22
Standard mounting flange.



HM23
Shock mount Flange to prevent structure bond vibration noise.



HM24
XLR-F flush socket with open end cable.



HM24C
XLR-F flush socket with cable and XLR-M plug



PRA518

Gooseneck microphone
5 versions to choose. Double bend or single bend. 31, 45, or 60 cm in length. Smallest capsule for sleek appearance.

Speech
Conference



- 518AS 31cm, Full bend
- 518AM 45cm, double bend
- 518AL 60cm, double bend
- 518BM 45cm, single bend
- 518BL 60cm, single bend

HM22 Screw lock flange included
S04 wind screen included



PRA538

Heavy duty gooseneck
Heavy duty thick gooseneck for heavier operation, and long lasting lifetime.

Speech
Announcement
Communication



- PRA538S 30 cm length with GT2C flange
- PRA538M 48 cm length with GT2C flange
- PRA538SS 30 cm fix mounted with DS-003 style base
- PRA538MS 48 cm fix mounted with DS-003 style base
- PRA538MS-PTT Push to Talk switch, remote control, GT2C flange
- S19 Wind screen included.



GT2B

Screw flange for 5/8" thread



PRA528

Gooseneck microphone
Compact capsule, standard plug or hidden pre-amp module for shorter base to meet conference room design requirements. Single bend.

Speech
Conference



- 528BL XLR base, 62cm
- 528BM XLR base, 47cm
- 528CL Wired XLR plug, 56cm
- 528CM Wired XLR plug, 41cm

HM23 Shock mount included for 'B'
HM22 Screw lock flange included for 'C'
S21 Wind screen included for all
S22 Wind screen optional



PRA528DS

Gooseneck with base
Proprietary weighted base for easy set up. Dual power with phantom or battery. Larger pop screen to prevent wind noise. Flush mount XLR-M socket for convenience.

Speech
Conference
Announcement



S18 Wind screen included
Battery 1.5V AA alkaline included



GT6F

XLR3F base, surface mount. With open end cable.



PRA618M

Gooseneck Microphone
Dynamic gooseneck for system with-out phantom power supply. M version is easy to use, plug and play. Especially for console talk back. MS version come with base.

Speech
Conference
DJ



- PRA618M XLR gooseneck, 45cm
- PRA618MS XLR with DS002S

S08 Wind screen included
HM22 Screw lock flange included for M version.
DS003 series recommended for PRA618M



E321

Gooseneck microphone
Condenser gooseneck with interchangeable capsules. Supplied with super cardioid cartridge. Cardioid and omni optional.

Speech
Conference



- AM100E10902AH Super cardioid standard
- Optional:
- AM100E10902AS Cardioid cartridge
- AM100E10902AO Omni cartridge

S20 Wind screen included



DS003

Gooseneck mic base
XLR3F to XLR3M socket for convenient connection.



D302 E306

Install Gooseneck Mic

These 2 gooseneck mics are designed for installation or integration into other system. D302 is dynamic with same capsule as PRA618M and E306 is electret condenser with same capsule as PRA528DS.

System Integration
Communication
Conference



- D302 30cm, Wire out
- E306 30cm, Wire out



Wire out bolt nut

NEW

ReNEW

NEW

Easy Place

Wherever....



E303

NEW

Acoustic Boundary

Uni-directional, white or black finish. Especially suitable for table top placement. Built-in power circuit for phantom power.

Speech
Piano
Tap dance
General purpose



E303W Cardioid, white
E303B Cardioid, black

Included Items
Cable 7.5-meter TA3F to XLR3M

E304

NEW

Acoustic Boundary

Omni directional, white or black finish. Especially suitable for table top placement. Built-in power circuit for phantom power.

Speech
Piano
Tap dance
General purpose



E304W Omni, white
E304B Omni, black

Included Items
Cable 7.5-meter TA3F to XLR3M

PRA52

Ceiling Mount Microphone

For ceiling mount applications such as choir and orchestra pick-up. Permanent attached 10 meter cable between capsule and power adapter. XLR output plug.

Choir
Strings
Winds



PRA52B Black version
PRA52W White version

Included Items
Steel bending bracket
S06 Wind screen



PRA418

Omni Acoustic Boundary
Omni directional acoustic boundary microphone. Suitable for recording and logging applications.

PRA428

Cardioid Acoustic Boundary
Cardioid directional acoustic boundary microphone. Suitable for live sound, or recording with background noise.



E323

NEW

Flush Mount Half Cardioid
Uni-directional directional versions. White or black finish. Especially suitable for table top flush mount. Built-in electronics with XLR-M plug.



E324

NEW

Flush Mount Omni Mic
Omni directional versions. White or black finish. Especially suitable for table top flush mount. Built-in electronics with XLR-M plug.

Speech
Piano
Tap dance
General purpose

Speech
Piano
Tap dance
General purpose

Speech
General purpose

Speech
Surveillances
General purpose



Included Items
PS418D Power adapter
Cable 7.5M TA3F plugs
Battery AA 1.5V alkaline

Included Items
PS418D Power adapter
Cable 7.5M TA3F plugs
Battery AA 1.5V alkaline

E323W Cardioid, white
E323B Cardioid, black

E324W Omni, white
E324B Omni, black



D401S

NEW

Omni Microphone
Omni microphone without proximity effect for best speech clarity. For places without feedback problem, omni become better choice than cardioid counterpart. Such as podcast, disptach, talkback... On/off switch included,



D105S

NEW

Vocal Microphone
A popular handheld microphone for contractor in system integration. On/off switch convenience operation.



PRA448

Flush Mount Microphone
Flush mount dynamic microphone for indoor and outdoor with stainless steel plate. Standard gang box plate size for easier installation. DPDT push switch for momentary on/off and remote control.



PRA535NC

Push-to-Talk Microphone
Heavy duty PTT microphone for communication. Noise cancelling version for high background noise environment to keep intelligibility. Remote control sync with PTT switch. 3.4M coil cable output.

Communication
Dispatch, Talkback
Language Labs
Podcast

Ballroom,
Convention center,
Conference facilities
Court house

Warehouse, Factory,
School, Restaurant,
Fast food, Apartments,
Security Access,

Announcement, Com-
munication, Transportation
vehicle, Security Access,
Emergency, Dispatch



HM38S Mic clip included
Recommended Item:
GM13D Gooseneck
DS003 Gooseneck base

HM38S Mic clip included
Mic pouch Carrying bag included

PRA448S On/off switch included

PRA535 Standard version
PRA535NC Noise cancelling

HM53 Wall bracket included

Wireless Microphones

People like freedom, no bounds, and certainly want to use everything without wires. Here you are.

RF transmission and reception is not difficult. Wireless with stable reception and convenient channel setting is a challenge. Superlux has achieved true diversity and channel management through years of research for this new UHF system with infrared channel control. The digital control system provides excellent stability and ease of use.

With a selection of Superlux microphones, the excellent sonic quality is available not only with wire, but also wireless now.

Less for more

Freedom



true diversity UHF



UT4 **NEW**

Handheld Transmitter

Hand held wireless microphone with choices of Superlux famous microphone capsules, dynamics as well as condensers. FIC technology allows easy RF channel synchronization.

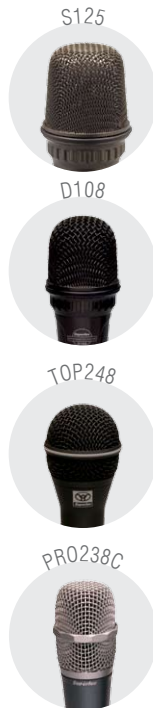

UT2 **NEW**

Body Pack Transmitter

Body pack wireless transmitter with choices of Superlux famous hands free microphones, dynamics as well as condensers. FIC technology allows easy RF channel synchronization. TA4M input socket to adapt various sources.



Recommended Capsules

- UT4/125: S125 condenser
- UT4/108A: D108A dynamic
- UT4/248: TOP248/PRO248 dynamic
- UT4/238C: PRO238C condenser

Recommended Microphones

- UT2/383: PRA383 condenser clip-on
- UT2/20: PRA20 dynamic headworn
- UT2/30: PRA30 condenser headworn
- UT2/10A: E10A condenser headworn
- UT2/10B: E10B condenser headworn
- UT2/518: W0518 condenser miniature

UT6 **NEW**

True Diversity Receiver

True diversity, dual reception systems guaranteed perfect signal continuity without dropout. Easy to use color information display, 1-button FIC frequency infrared communication syching transmitter and receiver.



Frequency Infrared control

Wireless Package Set



S125

UT64/125

Handheld set

UT4/125 Handheld transmitter
UT-6 Diversity Receiver



D108

UT64/108A

Handheld set

UT4/108A Handheld transmitter
UT6 Diversity Receiver



TOP248

UT64/248

Handheld set

UT4/248 Handheld transmitter
UT6 Diversity Receiver



PRO238C

UT64/238C

Handheld set

UT4/238C Handheld transmitter
UT6 Diversity Receiver



PRA20

UT62/20

Headworn Dynamic

UT2 Belt-pack transmitter
UT6 Diversity Receiver
PRA20TQG Headworn dynamic microphone



PRA30

UT62/30

Headworn Condenser

UT2 Belt-pack transmitter
UT6 Diversity Receiver
PRA30TQG Headworn condenser microphone



E10A

UT62/10A

Headworn Dynamic

UT2 Belt-pack transmitter
UT6 Diversity Receiver
E10ATQG Headworn condenser microphone



E10B

UT62/10B

Headworn Dynamic

UT2 Belt-pack transmitter
UT6 Diversity Receiver
E10BTQG Headworn condenser microphone



UT62G

E. Guitar set

UT2 Belt-pack transmitter
UT6 Diversity Receiver
GA03 Guitar Cable



PRA383

UT62/383

Instrument Set

UT2 Belt-pack transmitter
UT6 Diversity Receiver
PRA383 Mini clip-on gooseneck instrument mic



W0518

UT62/O518B

Speech set

UT2 Belt-pack transmitter
UT6 Diversity Receiver
W0518B/TQG Lavalier omni microphone

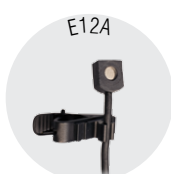

E12A

UT62/12A

Speech set

UT2 Belt-pack transmitter
UT6 Diversity Receiver
E12ATQG Miniature omni microphone

Wireless System Accessories



AT0

UDA28

TBA

UHF Antenna DA
Dual 1 input - 4 outputs
UHF antenna distribution system. 1 rack space.



RK1



RK2

AT0

TBA

Dipole Antenna
Dipole antenna

AT1

TBA

Directional Antenna
Directional antenna

RK1

Rack Mount Kit
Mount 1 UT6 into 1 rack space.

RK2

Rack Mount Kit
Mount 2 UT6 into 1 rack space.



Measurement Mic & others

See what's there, know what you've heard.

seeing is believing...

Precision



Professionals work based on quantization, to control the variables and make things happen exactly as predicted.

RTA



4U2SET

2 CH Real Time Analyzer

The world's only 2 channel RTA in palm size. Fast response surpassed predecessors. 1/3 octave, 31-band each channel. Package comes with 2 ECM888B and 2 HM-32 in a convenient carrying case.



ECM999

1/2" Measurement Mic.

Industry standard 1/2" phantom powered measurement microphone suitable for real time analyzer and PC based measurements. Due to its flat and wide frequency, it is also suitable for recordings.

Measurements
Recording



ECM888B

1/4" Measurement Mic.

Industry standard 1/4" dimension. 6V battery powered measurement microphone suitable for real time analyzer and PC based measurements. Due to its flat and wide frequency, it is also suitable for recordings.

Measurements
Recording



PINK STICK

Signal Generator

Phantom powered, no battery needed. Rotary switch operates this tiny generator with pink noise, 1KHz tone, and pulse for polarity check. Mute setting in between every signal for easy muting.

Measurements
Testing



HM10B Mic clip included
S02 Wind screen included



HM32 shock mount included
4LR44 Battery included

Accessories

Power adapters, phantom power suppliers, converters, adapters, microphone mounts, shock mounts, pop screens, stereo bars...

Convenience

gives you an important hand



Move what should be moved. Fix what should be fixed. Put the microphone at the spot you like and shield it from winds and vibrations.

HM43

Metal mesh wind screen

Specially designed for S241 studio condenser microphone. Also suitable for Ø 20~22mm high performance condenser microphones.



PS418D

Pre-Amp and Power Adapter

Provides power to miniature microphones from phantom power or battery. Switchable low cut filter helps to cut unnecessary low band in order to reduce noise.



PS418S

Pre-Amp and Power Adapter

Provides power to miniature microphones from phantom power. Tiny inline design minimized space requirements.



CP818

Impedance Adapter

Convert Lo-Z to Hi-Z, or vice versa. XLR-F to phone plug.



CP828

Impedance Adapter

Convert Lo-Z to Hi-Z, or vice versa. XLR-M to phone plug.



CP838

Impedance Adapter

Convert Lo-Z to Hi-Z, or vice versa. XLR-M to phone socket.



PS2A

Phantom Power Supplier

Provides 48V phantom power to 2 microphones. Auto ranging from 100VAC to 240VAC power source. Various power cords for different countries.



PS2B

Phantom Power Supplier

Provides 12V or 48V phantom power to 2 microphones. Powered by two 9VDC batteries or external AC adapter (not included).



A version shown

DS003

Gooseneck mic base

XLR3F to XLR3M socket for convenient connection.

DS003 Flushed XLR socket
DS003S Same as 003, with switch
DS003A Raised XLR socket with lock
DS003AS Same as 003A, with switch



DS002

Gooseneck mic base

XLR3F to XLR3M socket for convenient connection including on/off switch.

HM40
Shock Mount

Good shock mount is vital for demanding user.



HM54
Shock Mount



HM32
Shock Mount



YA10

Camera mount
Adapts 5/8" thread clips onto various cameras



HM35

Shock mount
Suitable for Ø15~27mm microphones



HM42

Universal clip
Suitable for Ø24~32mm microphones



HM9

Universal clip
Suitable for Ø20~35mm microphones



HM35C

Camera shock mount
Suitable for Ø15~27mm microphones mount onto cameras



HM101

Universal clip
Suitable for Ø16~45mm microphones



HM10

Universal clip
Suitable for Ø19~24mm microphones



HM37

Universal clip
Suitable for Ø18~20mm microphones



HM54

Shock mount
Suitable for Ø24~40mm microphones



HM29

Universal wireless clip
Suitable for Ø29~39mm microphones



HM38

Universal clip
Suitable for Ø24~26mm microphones

Suffix indications

- A plastic thread
- B metal thread
- C camera mount
- S screw know, metal thread



HM30

Shock mount
Suitable for Ø24mm microphones such as PRO218A and PRA218B



HM39

Universal wireless clip
Suitable for Ø32~38mm microphones

Clips
mm

Model	Ø or Mic #
HM8	CM-H8, excl. 8K
HM9	20~35
HM10	19~24
HM16	23~30
HM29	29~39
HM37	18~20
HM38	24~26
HM39	32~38
HM42	24~32
HM101	16~45

Shock Mounts
mm

Model	Ø or Mic #
HM7	CMH8, excl. 8K
HM30	PRO218
HM54	24~40
HM32	20~26
HM33	22~24
HM35	15~27
HM40	12~30
HM40C	12~30



HM32

Shock mount
Suitable for Ø20~26mm microphones



HM40

Shock mount
Suitable for Ø12~30mm microphones



HM33

Shock mount
Suitable for Ø22~24mm microphones



HM40C

Camera shock mount
Suitable for Ø12~30mm microphones

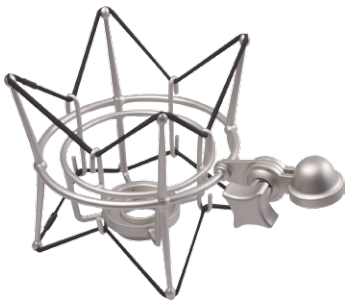

HM7

Shock mount

For CMH8A/ 8B/ 8C/ D/ G/ AH/ BH/ CH. Minimized vibration noise to un-noticeable.



HM26A B C

Shock mount

A version for CMH8A/8B/8C/D/G/AH/ BH/CH
 B version for Ø22~26mm microphone
 C version for H08



HM31

Shock mount

For R102. Minimized vibration noise to un-noticeable.



C2

Dual mic adapter

Variable distance between 6~17CM

MA90

Stereo bar

Suitable for various stereo recording.
 Length: 620 mm
 Weight: 0.64 kg
 Microphone angle detented every 15°

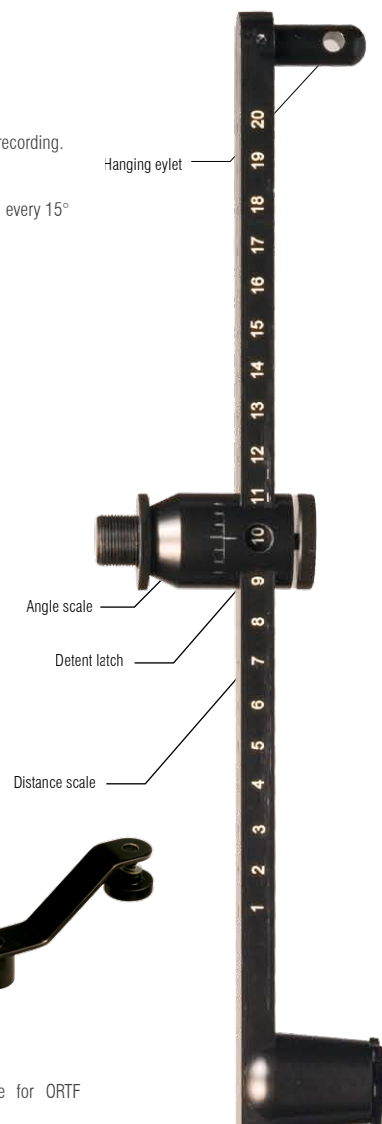

HM15

Dual mic adapter

Fix 17cm space, suitable for ORTF setup.



Clips, Drum clips



DMC01

Drum clip
Clamps to drum flange, rod sticks...
3/8" screw for mic clips.



DMC02

Drum clip
Clamps to drum flange, rod sticks...
3/8" screw for mic clips.



DMC03

Drum clip
Clamps to drum flange, rod sticks...
3/8" screw for mic clips.

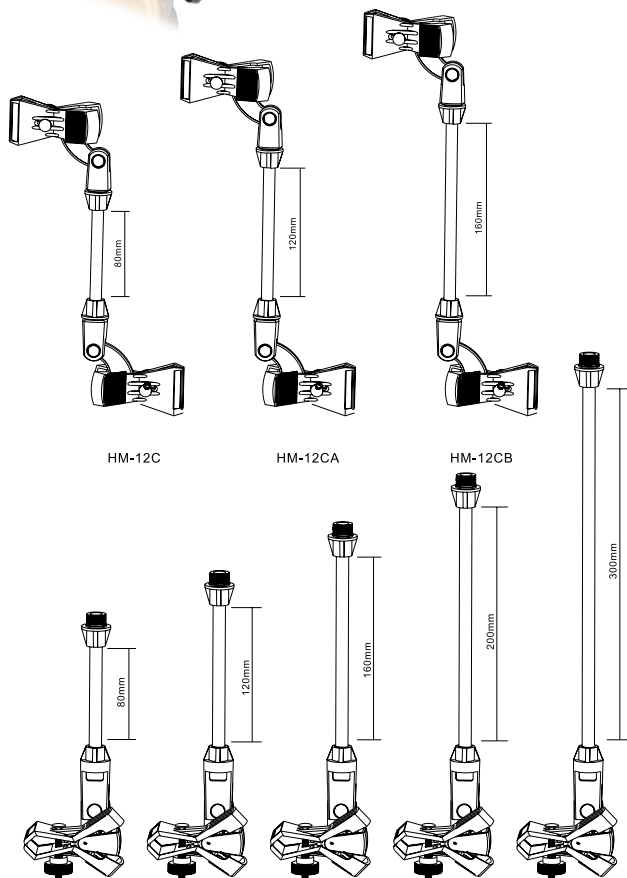

HM-12C

HM-12CA

HM-12CB

HM-12D

HM-12DA

HM-12DB

HM-12DC

HM-12DD



HM12A

Universal clamp
Clamps to drum flange, rod sticks...
5/8" screws for mic clips.



HM12E

Universal clamp
Clamps to drum flange, rod sticks...
5/8" thread for adapting to other accessories.



HM12F

Universal clamp
Double clamps to drum flange, rod sticks, or microphone



HM12C CA CB

Universal clamp
Double clamps to drum flange, rod sticks, or microphone. 3 lengths at 80mm, 120mm, and 160mm



HM12D DA DB DC DD

Universal clamp
Clamps to drum flange, or rod sticks,
5/8" screw for mic clips. 5 lengths at 80mm, 120mm, 160mm, 200mm, and 300mm.



HM25

Drum clamp
Clamps to drum flange, with variable distance mic clips to adjust ideal miking position.

Foam Windscreens



S02
Measurement Mic Foam
For \varnothing 7~10mm microphone, such as ECM999.



S04
Gooseneck Mic Foam
For \varnothing 7~10mm microphone, such as PRA518.



S08F
Pencil Mic Foam
For \varnothing 20mm microphone, such as CMH8K.



S09
Instrument Mic Foam
For \varnothing 23~30mm microphone, such as E124.



S09F
1/2" small diaphragm Foam
For \varnothing 22mm microphone, such as S241.



S11
Headworn Mic Foam
For \varnothing 10-18mm microphone, such as PRA20/30.



S12
Miniature Mic Foam
For 8mm microphone, such as W0518 and WU518.



S25
E524D Foam
For E524D stereo XY microphone.



S65
Large Mic Foam
For \varnothing 50~55mm microphone, such as CMH8 series



S40
Vocal Mic Foam
For \varnothing 46-52mm microphone, 5 colors to choose



Model	Inner \varnothing	Depth	Max. \varnothing	For Mic \varnothing	Microphone	Color
S02	6	25	21	7~10	ECM999	
S04	6	31	25	7~10	PRA518	
S06	10	13	18	10~15	PRA52	BK, WH
S07	21	55	46	22~30	PRA318S/L, E531	
S08F	20	19	35	20	CMH8K	
S09	22	52	46.5	23~30	E124	
S09F	22	36	46.5	22	S241	
S11	16	17	28	10~18	PRA20/30	
S12	8	5	11	8	W0(U)518	
S13	8	5	20	8	W0(U)518	
S14	17	260	43	18~21	PRA116B, 118S	
S15	17	390	43	18~21	PRA118L	
S18	20	52	38	21~29	PRA528DS	
S19	NA	NA	NA	30~34	PRA538	
S20	18	32	45	19~25	E109	
S21F	12.5	20	27	12.5	E322, PRA528B, C	BK, WT
S22F	12.5	20	24	12.5	E322, PRA528B, C	BK, WT
S23	NA	NA	NA	NA	E10A, E10B	BK, BG
S25	NA	NA	NA	NA	E524D	
S27	6	25	21	7~10	E102	
S40	50	60	55	46~52	Handheld Vocal	BK, BL, GN, RD, YL
S50	35	71	70	35~55	E522, 523	
S53	NA	18	23	NA	E12A	
S65	46	90	52	50~55	CM-H8	

F suffix indicates frame inside.



S15



S14

Cables, signal to power

Quality connectors, conductors, and insulators are vital to signal transmission

Plug 'n' Play

delivering music...



FAIRLINE features

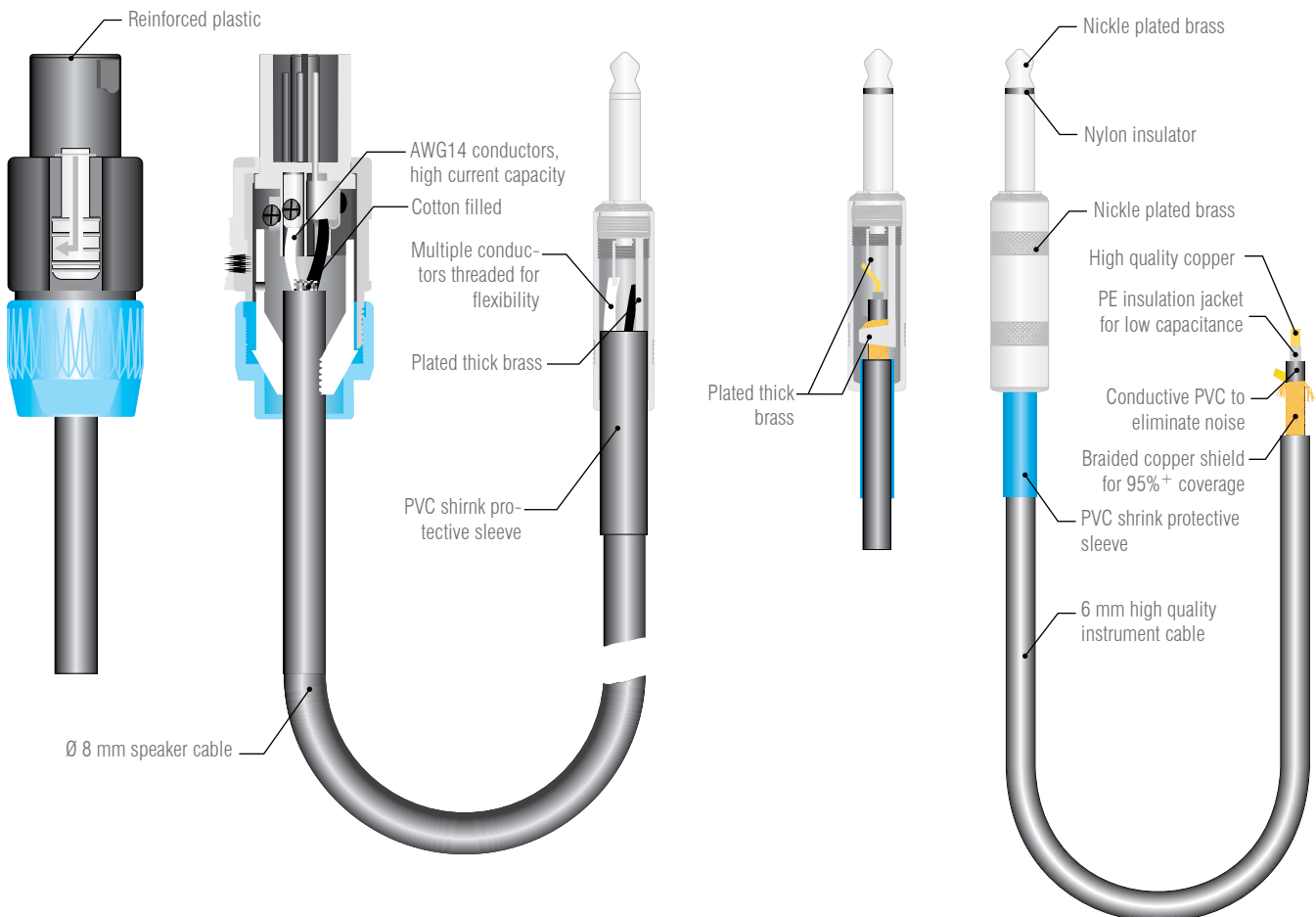

FAIRLINE cable series

Instrument signal cable

Angle 1/4" mono phone plugs

Model	Length
SFI0.3RR	0.3M
SFI0.6RR	0.6M
SFI0.9RR	0.9M
SFI1.5RR	1.5M
SFI3RR	3M
SFI6RR	6M

Straight 1/4" mono phone plugs

Model	Length
SFI0.3PP	0.3M
SFI0.6PP	0.6M
SFI0.9PP	0.9M
SFI1.5PP	1.5M
SFI3PP	3M
SFI4.5PP	4.5M
SFI6PP	6M

Straight and angle 1/4" mono phone plugs

Model	Length
SFI0.9PR	0.9M
SFI1.5PR	1.5M
SFI3PR	3M
SFI4.5PR	4.5M
SFI7.5PR	7.5M

Speaker cable, AWG#14

Speakon plugs, 2 conductors

Model	Length
SFS3SS	3M
SFS5SS	5M
SFS10SS	10M
SFS15SS	15M
SFS20SS	20M

1/4" mono plugs

Model	Length
SFS3PP	3M
SFS5PP	5M
SFS10PP	10M
SFS15PP	15M
SFS20PP	20M

Speakon and 1/4" mono plug

Model	Length
SFS0.9SP	0.9M
SFS3SP	3M
SFS9SP	9M

Balanced signal cable

XLR3F to XLR3M, AWG# 24

Model	Length
SFM0.5FM	0.5M
SFM1.5FM	1.5M
SFM2.5FM	2.5M
SFM5.0FM	5M
SFM7.5FM	7.5M
SFM10FM	10M
SFM20FM	20M

Un-balanced signal cable

XLR3F to 1/4" phone plug, AWG# 24

Model	Length
SFM5FP	5M
SFM7.5FP	7.5M
SFM10FP	10M

Bulk roll

100 meters roll package

SFM 100, AWG# 24 balanced signal cable

SFI 100, instrument signal cable

SIS 100, AWG#14 speaker cable

Color code

Various color available for bulk roll. Please suffix color code while ordering

	BK	Black
	BL	Blue
	YL	Yellow
	GN	Green
	GR	Gray
	RD	Red
	VL	Violet

ECO cable series

Balanced signal cable

XLR3F to XLR3M, AWG# 24

Model	Length
CFM0.5FM	0.5M
CFM1FM	1M
CFM2.5FM	2.5M
CFM5.0FM	5M
CFM7.5FM	7.5M
CFM10FM	10M
CFM20FM	20M

Un-balanced signal cable

XLR3F to 1/4" phone plug, AWG# 24

Model	Length
CFM5FP	5M
CFM7.5FP	7.5M
CFM10FP	10M

Instrument signal cable

Straight 1/4" mono phone plugs

Model	Length
CFI0.3PP	0.3M
CFI0.6PP	0.6M
CFI0.9PP	0.9M
CFI1.5PP	1.5M
CFI3PP	3M
CFI4.5PP	4.5M
CFI6PP	6M
CFI9PP	9M

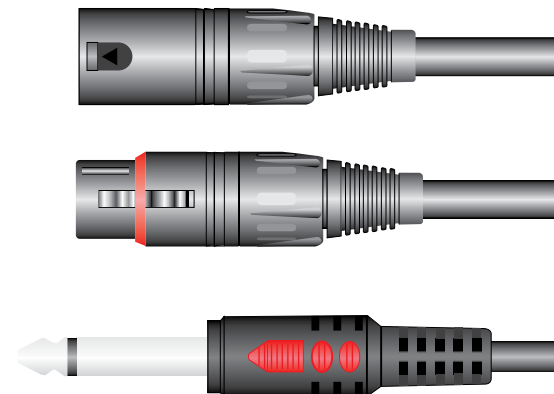

Headphones, Headsets

Listen and talk comfortably with high quality headphones and headsets.

Solitude Hour

Whisper at your ears

Precision and comfort are the vital factors to a high quality headphone. Superlux developed proprietary drivers with precision electroacoustics performance and long term wearing comfort, so that suitable for extended hours of using without hearing fatigue. Integrated with Superlux high quality wearing microphone elements, headphone become headset, that meets the demands of pro users.



Proprietary drivers *by Superlux*



HD660

Monitor Headphone
Precision sound reproduction performance makes HD660 suitable for critical monitor purpose



HD330

Headphone
Enhanced sound reproduction makes HD330 suitable for easy music listening, and for engineers to simulate the general public listening experience.



HMD660

NEW

Dynamic headset
Precision headphones with PRA20 professional wearing dynamic capsule. For sports live broadcast and similar applications.



HMC660

NEW

Condenser headset
Precision headphones with PRA30 professional wearing condenser capsule. For sports live broadcast and similar applications.

Monitor General purpose	General purpose	Broadcast Pro Sound Engineer	Broadcast Pro Sound Engineer
		🎧 🎙️	🎧 🎙️
1~3M coil spring cord	1~3M coil spring cord	1~3M Coil spring cord for open end 1.5M straight cord for X and E version	1~3M Coil spring cord for open end 1.5M straight cord for X and E version
HD660 3.5mm & 6.3mm stereo plug with spring coil cable	HD330 3.5mm & 6.3mm stereo plug with spring coil cable	HMD660 Open ends HMD660X 3.5mm stereo headphone plug with 6.3mm adapter, and XLR mic plug. HMD660E 3.5mm stereo headphone plug with 6.3mm adapter, and 3.5mm stereo mic plug wired as mono.	HMC660 Open ends HMC660X 3.5mm stereo headphone plug with 6.3mm adapter, and XLR mic plug. HMC660E 3.5mm stereo headphone plug with 6.3mm adapter, and 3.5mm stereo mic plug wired as mono.

Loudspeakers

Loudspeakers should be LOUD enough and work smoothly with no audible distortion. True value by sound.

Power Touch

echoes your beats

Superlux is committed to produce high quality loudspeakers the same as Superlux does for the microphones. Only sound counts - audiences must be satisfied first.

Excellent performance, and price within reach.



Plastic & Power



NEW ACTIVE Design

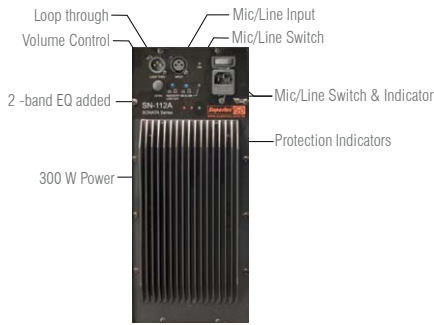

SN112A

NEW

Active 12" 2-way speaker

Built 300 + 100 watts power amplifier with active crossover network. Active dynamic control for maximum performance and trouble free operation.

Reinforce plastic box
3" voice coil LF unit
1.75" HF horn driver
300 W rms power



SN115A

NEW

Active 15" 2-way speaker

Built 300 + 100 watts power amplifier with active crossover network. Active dynamic control for maximum performance and trouble free operation.

Reinforce plastic box
3" voice coil LF unit
1.75" HF horn driver
300 W rms power



SN110

10" 2-way speaker

Light weight, easy to carry small PA box for smaller venue.

Reinforce plastic box
2" voice coil LF unit
1.75" HF horn driver
200 Watts RMS



SN112

12" 2-way speaker

Popular size plastic box. Precision sound and distant throw ability. 300 watts continuous power handling.

Reinforce plastic box
3" voice coil LF unit
1.75" HF horn driver
300 Watts RMS



SN115

15" 2-way speaker

Extended low frequency reproduction specially for music with bass performance. 500 watts continuous power handling.

Reinforce plastic box
3" voice coil LF unit
1.75" HF horn driver
500 Watts RMS



SN118S

18" sub woofer

Extending the deep bass for the plastic boxes. 4" voice coil capable of handling 600 watts of continuous power, reaching 130+ dB SPL.

18mm MDF box
4" voice coil
600 Watts RMS

Wood & Fly



SM12/F

12" 2-way speaker

Multiply birch plywood. Fly version available. High power bass and horn driver.

300 watts RMS



SM15/F

15" 2-way speaker

Multiply birch plywood. Fly version available. High power bass and horn driver.

350 watts RMS



SM112/F

12" 2-way speaker

Multiply birch plywood. Fly version available. High power bass and horn driver.

600 watts RMS



SM115/F

15" 2-way speaker

Multiply birch plywood. Fly version available. High power bass and horn driver.

600 watts RMS



SM215

Dual 15" 2-way speaker

Multiply birch plywood. Fly version available. High power bass and horn driver.

1200 watts RMS

LINE ARRAY

SA28

NEW

Line Array, Module

Multiply birch plywood box with scratch resist paint. Dual 8" high power MLF driver with dual 2" high power horn driver.

Dual 8"

Birch plywood

350 Watts rms

SA118S

NEW

Line Array, Subwoofer

Multiply birch plywood box with 18" bass reflex for deepest low frequency reproduction.

18" bass reflex

Birch plywood

600 Watts rms



SA215S

NEW

Line Array, Subwoofer

Multiply birch plywood box with folded horn loading dual 15" bass drivers.

Dual 15"

Folded Bass Horn

Birch plywood

1200 Watts rms



First Step

make a good start

From professional audio products, Superlux always cares about providing the same quality consumer audio products as well. After all, we are all consumers at some time.





HD440

Stereo Headphone

To experience your games and music, HD440 is the right choice for personal entertainment covering stereo to Dolby headphone for surround reality. Enhanced bass reproduction for ultimate personal entertainment experience.

Personal Entertainment

- Gaming
- AV surround experience



E531B

MS Stereo Microphone

MS setup capsules. For live recording, realism spatial capturing. 90° and 120° setting to control stereo width. Integrated with power switch for reducing battery consumption. Permanent attached cable with 3.5mm stereo angle plug.

Digital recording
DV/DAT/MD
Concert logging

- Easy to use
- Permanent attached cable
- 90° and 120° stereo width
- Power switch with LED indicator
- Battery power



E522B

NEW

XY Stereo Mic, Battery

Matched pair capsules. For live recording, realism spatial capturing. Unbalanced stereo output for amateur/consumer audio/video system. Internal low-cut switch for reducing noise. Battery power with on/off switch.

Broadcast/TV
Amateur recording
DV/DAT compatible

- Matched capsules
- Stereo unbalanced output
- Battery power
- On/off switch with locking plate
- Internal low cut switch



1.5 meters straight cable, 3.5mm stereo plug with 6.3mm adapter.

HM29A Clip & base
S07 Windscreen Included
Optional items:
Conversion cable: 3.5mm stereo socket to 2 x 6.3mm mono plug



Included items:
HM38S Mic clip
Mic cable 1 3M, XLR3F to stereo 3.5mm plug
Mic cable 2 0.5M, XLR3F to stereo 3.5mm angle plug
Mic pouch
Battery 1.5V AA alkaline
Optional items:
HM40C Camera shock mount
S50 Wind screen
Conversion cable: 3.5mm stereo socket to 2 x 6.3mm mono plug



D106

Dynamic microphone

Low cost super cardioid microphone for general applications. Comes with 3.5mm plug and 3.5 to 6.3mm adapter. A convenient choice for MA500 or MA818. On/off switch.



D10A

Dynamic microphone

Omni directional microphone without handling noise. Suitable for home recordings as well as general applications. Belt clip for easy store away while not in use, a good match for MA500, also works well with MA818.



E210

Miniature Microphone

Comprises EM210 omni directional microphone, PS210 battery power adapter. 3M cable. Tie clip. For portable PA application, EM210 1.5M cable only supplied with MA500 or MA818.



E302

Mini Test Microphone

Omni measurement microphone. Specially designed for home theater automatic alignment setting. Permanent attached cable with 3.5mm stereo plug. Suitable for popular plug-in power mic inputs.

Students
Net meeting

General Application
Net meeting

Teacher
Mobile retail stands
Compact PA system

Home theater
PC/Notebook



- HM42A included
- 3M cable
- Optional stand DS106



- Belt clip
- 1.5M cable with 3.5mm stereo plug wired as mono
- Optional stand DS106



- Including Items:
- EM210 microphone with 3M cable
 - Tie clip
 - PS210 battery power adapter
 - Battery 1.5V AA alkaline



- Simple to use
 - Table stand included
 - 5 meters cable
- DS01 Mini table stand included
HM9B Mic clip included

HUGO

Features

MA818

NEW

Portable mini-PA

Light weight portable PA for convenient speaking and music reinforcement. Shoulder strap for voice-on-the-move. 5" full range, high efficient driver driven by 27 watts power amplifier is power enough for tenths of people gathering. 5/8" thread located at the bottom for mounting MA818 onto a microphone stand.

Tour Guide School Teacher Presenter

- 5" high efficient driver
- 27 watts power
- 12V 2.7AH rechargeable battery pack, 8 hours operation, 4 hours charging.
- 50Hz~18KHz
- THD < 1%
- Dimension 285 x 160 x 178mm
- Weight 3kg
- 90~260VAC charger / AC adapter



- 12V 2.7AH rechargeable battery
- Hi power 5" full range driven by 27 watts power amp
- Wireless volume and power switch
- Wired mic volume
- Power indicator
- 3.5mm line output
- 3.5mm line input
- DC input
- 5/8" thread socket
- 6.3mm wired mic input

Wireless version shown



MA818/535NC

PTT NC pack
MA818 packed with PRA535NC PTT microphone for best background noise rejection.



MA818/105

Headworn cardioid
MA818 packed with E105 headworn cardioid microphone for hands free operation. For smaller and quiet space with warmer sound. 3.5mm to 6.3mm adapter included.



MA818/108

Headworn figure 8
MA818 packed with E108 headworn figure 8 microphone for hands free and back ground noise rejection. 3.5mm to 6.3mm adapter included.



MA818/210

Lavalier pack
MA818 packed with EM210 lavalier microphone. 3.5mm to 6.3mm adapter included.



MA818/10A

Handheld pack
MA818 packed with D10A omni microphone with no proximity effect and tuned frequency response for the good intelligibility. 3.5mm to 6.3mm adapter included.



MA818/106

Handheld pack
MA818 packed with D106 handheld super cardioid microphone, matched with a HM42A mic clip. At smaller and quiet space, this popular style microphone meets common expectation with minor proximity effect with warmer sound.

Optional DS106 table stand for microphone.

S M A L L SIZE LOAD

MA500

NEW

Personal voice enhancer

Very light weight portable PA can be strap to waist as a belt pack. Powered by 6 x AA alkaline batteries or rechargeable batteries. High efficient 2.5" driver driven by 5 watts power amplifier. Specially designed for kindergarten teacher and mobile retail stands.

School Teacher
Mobile retail stands
Tour Guide

- Mic and line inputs
- AA Batteries operated (not included)
- 5 watts power, 8 hour operation
- 2.5" high efficient driver
- 320 g (without batteries)



MA500/105

Headworn cardioid

MA818 packed with E105 headworn cardioid microphone for hands free operation. For smaller and quiet space with warmer sound.



MA500/108

Headworn figure 8

MA818 packed with E108 headworn figure 8 microphone for hands free and back ground noise rejection.



MA500/210

Lavalier pack

MA818 packed with EM210 lavalier microphone



MA500/10A

Handheld pack

MA818 packed with D10A omni microphone with no proximity effect and tuned frequency response for the good intelligibility.



NEW

E105

Cardioid Headworn

Back electret condenser cardioid microphone specially design for close-up miking as headworn always keep the microphone at a very short distance. New design to organize the cable neatly. 3.5mm stereo plug wired as mono output covering popular microphone interface.

Teacher
Mobile retail stands
Compact PA system



Included Items:
S23 Wind screen
Recommended Items:
PS210 Battery power adapter

NEW

E108

Figure 8 Headworn

Back electret condenser figure 8 microphone for noise cancelling. Excellent surrounding sound rejection. High gain before feedback for live stage. 3.5mm stereo plug wired as mono output covering popular microphone interface.

Speech in noisy environment



Included Items:
S23 Wind screen
Recommended Items:
PS210 Battery power adapter

Stands

Important support to the equipment, and even more important to support your business.

STAND *Music* ING

UNDER

to provide support



MS107

Mic Stand

Height: 80~150 cm
Weight: 3.23 kg
Material: Steel
Base: Cast-iron

MS101

Mic Stand

Height: 90~160 cm
Weight: 2.5 kg
Material: Steel
Base: Die-Cast

MS110

Mic Stand

Height: 80~150 cm
Weight: 4 kg
Material: Steel
Base: Cast-iron

MS300

High Rise Stand

Height: 165~350 cm
Boom length: 125~205 cm
Weight: 9.75 kg
Material: Steel
Base: Plastic

Telescopic Boom

Cable clips

Extra Large Tilt Control

Adjustable Counter Weight

Casters with brake

E
BAG

Bigfoot Willie Featured. One of the 3 legs is extendable to enhance stability. A new and patent pending design. Comes with a convenient carrying bag.

Patent Pending



MS131 E/BAG

Adjustable Boom Stand
 Height: 90~160 cm
 Boom length: 45~80 cm
 Weight: 3.25 kg
 Material: Steel
 Base: Zinc Alloy Die-Cast



MS108 E
MS108 E/BAG

Boom Stand
 Height: 90~150 cm
 Boom length: 80 cm
 Weight: 2 kg
 Material: Steel
 Base: Plastic
 MS108E: Variable length leg for extra stability



MS141 E/BAG

Boom Stand
 Height: 90~160 cm
 Boom length: 80 cm
 Weight: 3.33 kg
 Material: Steel
 Base: Die-Cast



MS152 E/BAG

Boom Stand
 Height: 90~160 cm
 Boom length: 80 cm
 Weight: 3.4 kg
 Material: Steel
 Base: Die-Cast



MS153 E/BAG

Adjustable Boom Stand
 Height: 90~160 cm
 Boom length: 45~80 cm
 Weight: 3.38 kg
 Material: Steel
 Base: Die-Cast

MICROPHONE BOOM STANDS



MTS024

Table Stand
 Height: 42~57 cm
 Weight: 2.41 kg
 Material: Steel
 Base: Cast-iron



MTS004

Table Stand
 Height: 30~45 cm
 Weight: 2.3 kg
 Material: Steel
 Base: Cast-iron



MTS014

Table Boom Stand
 Height: 40~50 cm
 Boom: 36 cm
 Weight: 2.5 kg
 Material: Steel
 Base: Cast-iron



MS105

Adjustable Boom Stand
 Height: 30 cm
 Boom length: 45~80 cm
 Weight: 2.5 kg
 Material: Steel
 Base: Die-Cast



MS200

High Rise Stand
 Height: 165~350 cm
 Boom length: 125~205 cm
 Weight: 9.75 kg
 Material: Steel
 Base: Plastic



MS104

Adjustable Boom Stand
 Height: 40~50 cm
 Boom length: 45~80 cm
 Weight: 2.61 kg
 Material: Steel
 Base: Die-Cast



HM6

Table Stand
 Height: 15~20 cm
 Weight: 0.4 kg
 Material: Zinc Alloy
 Base: Die-Cast
 HM9A Mic clip included



DS01

Table Stand
 5/8" thread
 Height: 11 cm
 Weight: 0.08 kg
 Material: Steel
 Base: Plastic

DS-011 HM-101A clip included



D1

Table Stand
 Height: 12 cm
 Weight: 0.5 kg
 Material: Steel
 Base: Cast-iron



HM48B

Table Arm

Weight: 1.2 kg

Material: Steel

Base: HM501, Elevated base,
HM502 Table edge clamp,
HM503, low profile base



HM58B

Table Arm

Weight: 1.2 kg

Material: Steel

Base: HM501, Elevated base,
HM502 Table edge clamp,
HM503, low profile base



MA91

Large pop screen

Ø 185mm double layer nylon fabric for wide coverage. Adjustable tilting.



HM501 Elevated base
HM502 Table edge clamp
HM503 low profile base

HM501 HM502 HM503

HM18AG

Pop screen

Package includes 2 filters: Metal mesh and nylon fabric for different result. Photo shown with not included D-1 table stand.





SPS410A

Aluminum Speaker Stand

Height: 115~200 cm

Capacity: 50 kg

Weight: 3.5 kg

Material: Aluminium

Finish: Aluminium original

SPS410AB Black version



SPA01

Subwoofer pole

For supporting a main speaker on top of a subwoofer which incorporating a speaker post hole. Fit 35mm holes.

Height: 92~160 cm

Capacity: 50 kg

Weight: 1.83 kg

Material: Steel

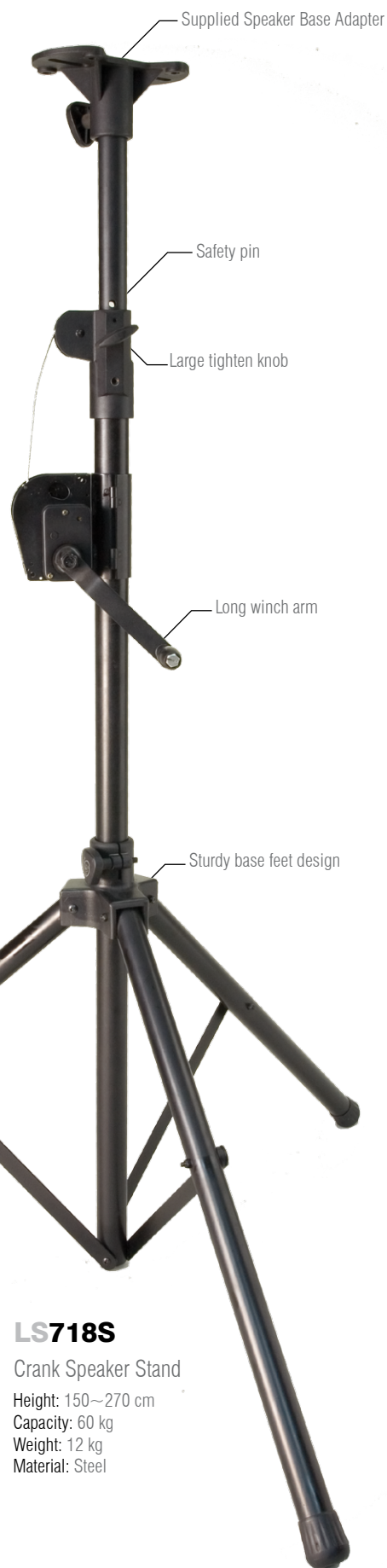

LS718S

Crank Speaker Stand

Height: 150~270 cm

Capacity: 60 kg

Weight: 12 kg

Material: Steel



SPS410B

Steel Speaker Stand

Height: 115~200 cm

Capacity: 50 kg

Weight: 5.5 kg

Material: Steel

Finish: Black paint

SPSK1

Speaker Stand Package

Includes:

1 x SPS410B

1 x SPA01

1 x Large carrying bag



SPSK2

Speaker Stand Package

Includes:

2 x SPS410B stands

1 x Large carrying bag



SPS400

Indoor Speaker Stand

Height: 100~160 cm
Capacity: 20 kg
Weight: 2.8 kg
Material: Steel



SPS430L

Monitor Speaker Stand

Height: 90~114 cm
Capacity: 25 kg
Weight: 7 kg
Material: Steel

SPS838

Ceiling/wall mount

Capacity: 10 kg
Weight: 1 kg
Material: Steel

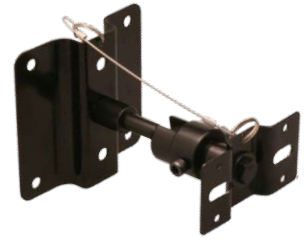

SPS867A

Ceiling/wall mount

Height Adj: 20~27cm
Capacity: 25 kg
Weight: 2.2 kg
Material: Steel



SPS868

Ceiling/wall mount

Capacity: 25 kg
Weight: 2.1 kg
Material: Steel

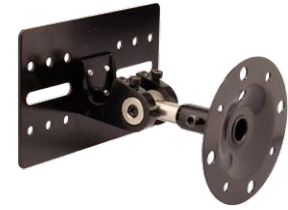

SPS878

Ceiling/wall mount

Capacity: 30 kg
Weight: 3.9 kg
Material: Steel

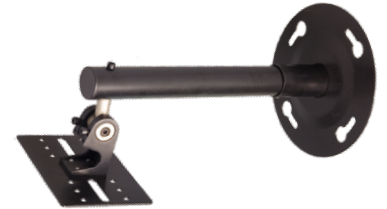

SPS813

PA speaker wall mount

Capacity: 50 kg
Weight: 13.5 kg
Material: Steel



SPS823

Wall mount

Capacity: 50 kg
Weight: 4.63 kg
Material: Steel



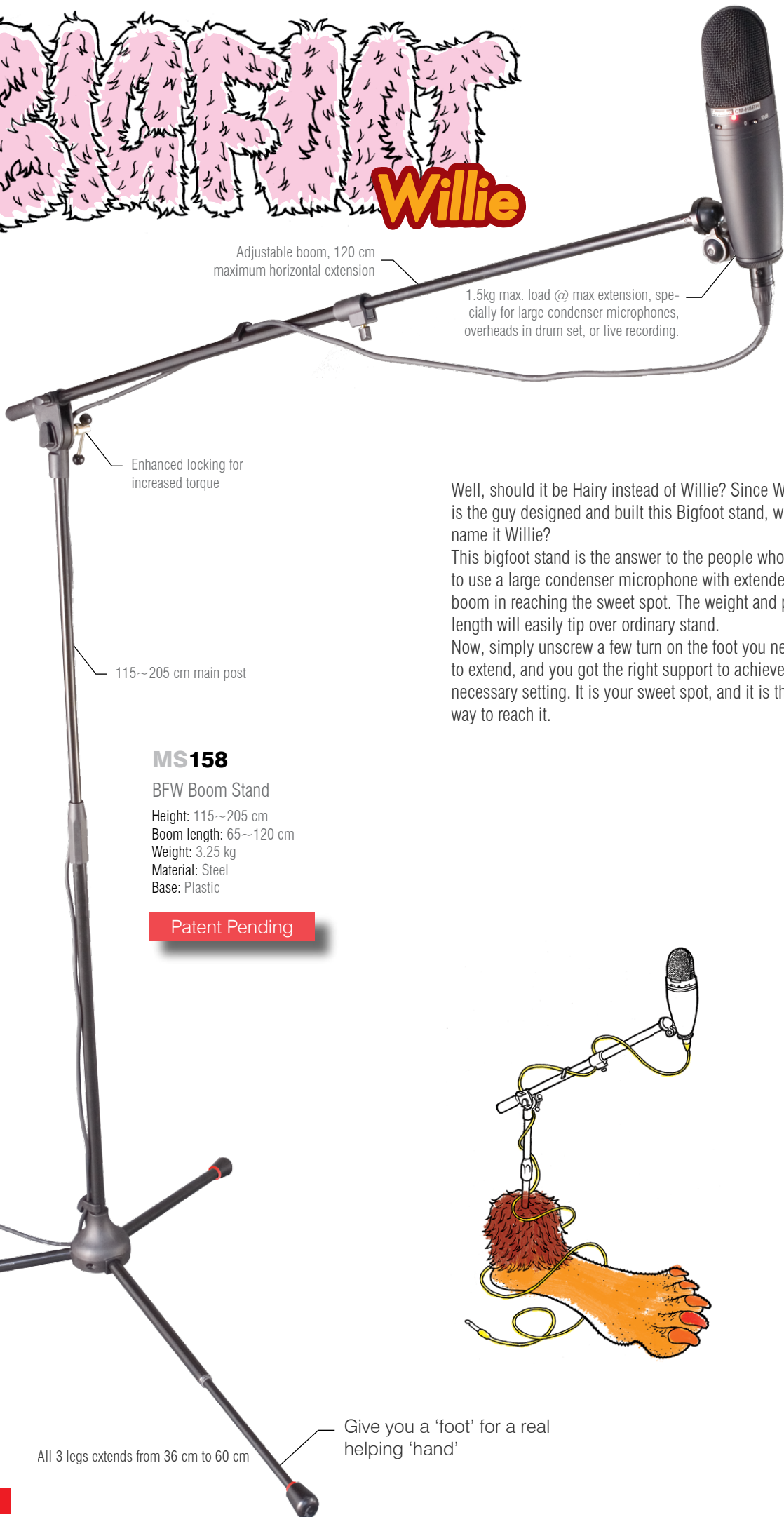

Adjustable boom, 120 cm maximum horizontal extension

1.5kg max. load @ max extension, specially for large condenser microphones, overheads in drum set, or live recording.

Enhanced locking for increased torque

115~205 cm main post

Well, should it be Hairy instead of Willie? Since Willie is the guy designed and built this Bigfoot stand, why not name it Willie?

This bigfoot stand is the answer to the people who want to use a large condenser microphone with extended boom in reaching the sweet spot. The weight and power length will easily tip over ordinary stand.

Now, simply unscrew a few turn on the foot you need to extend, and you got the right support to achieve the necessary setting. It is your sweet spot, and it is the right way to reach it.

MS158

BFW Boom Stand

Height: 115~205 cm

Boom length: 65~120 cm

Weight: 3.25 kg

Material: Steel

Base: Plastic

Patent Pending

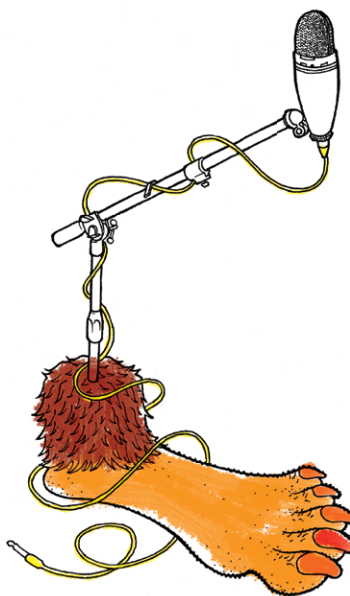

All 3 legs extends from 36 cm to 60 cm Give you a 'foot' for a real helping 'hand'



DS70

Display Rack

Weight: 10 kg
Material: Steel
Includes: 20 x display hooks

RS921

21U Rack

Weight: 22 kg
Material: Steel
Includes: Empior and metric screws



RS916

16U Rack

Weight: 19.5 kg
Material: Steel
Includes: Empior and metric screws



RS912

12U Rack

Weight: 17.5 kg
Material: Steel
Includes: Empior and metric screws



RS908

8U Rack

Weight: 15.6 kg
Material: Steel
Includes: Empior and metric screws



Charts and specifications 1

- 1 CMH8A
- 2 CMH8AH
- 3 CMH8B
- 4 CMH8BH
- 5 CMH8C
- 6 CMH8CH
- 7 CMH8D
- 8 CMH8E
- 9 CMH8G
- 10 CMH8K
- 11 D103
- 12 D105S
- 13 D106
- 14 D108A
- 15 D109
- 16 D10A
- 17 D10B
- 18 D112
- 19 D302
- 20 D401
- 21 E100
- 22 E101
- 23 E102
- 24 E109
- 25 E10A
- 26 E10B
- 27 E12A
- 28 E124D
- 29 E210

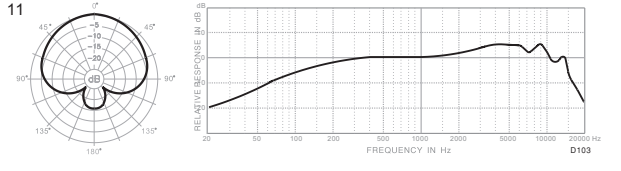
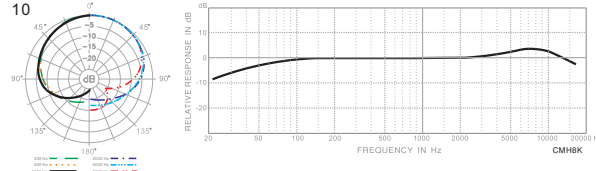
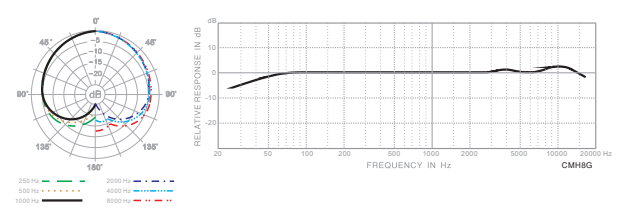
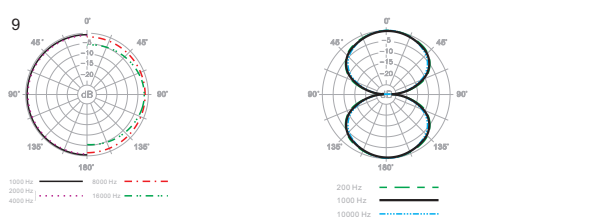
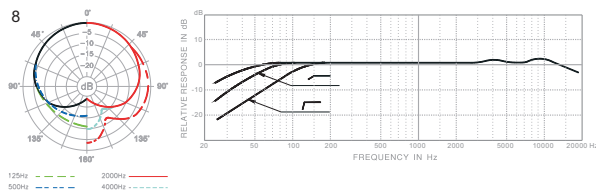
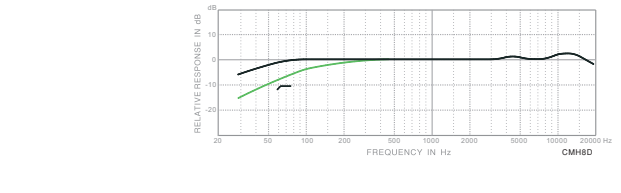
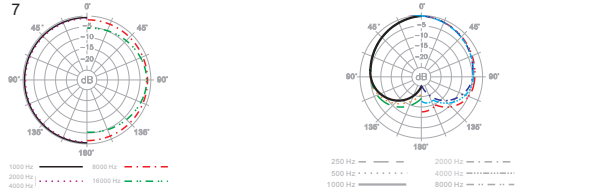
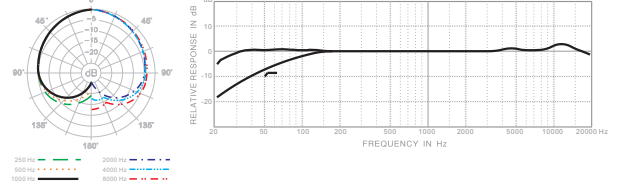
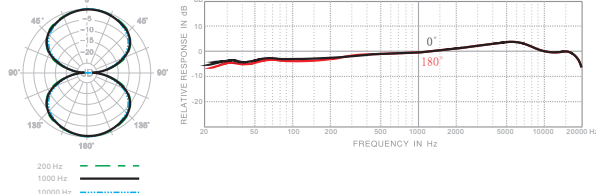
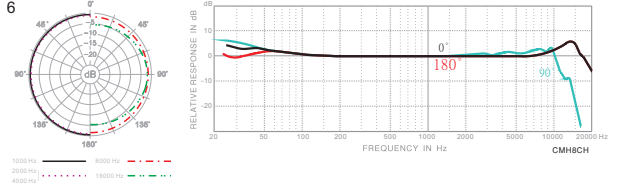
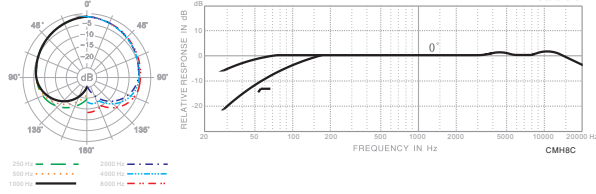
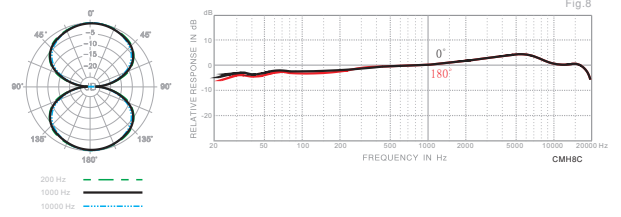
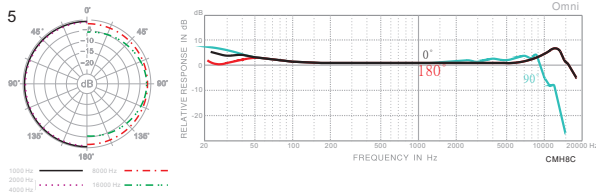
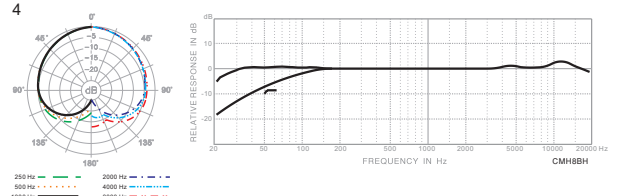
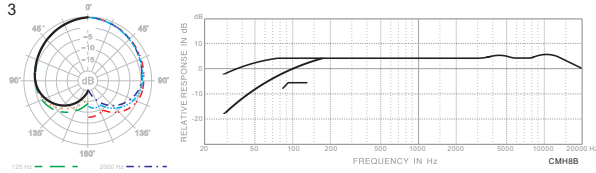
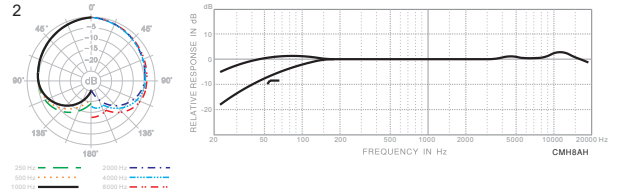
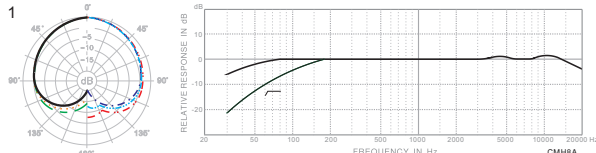

Charts and specifications 2

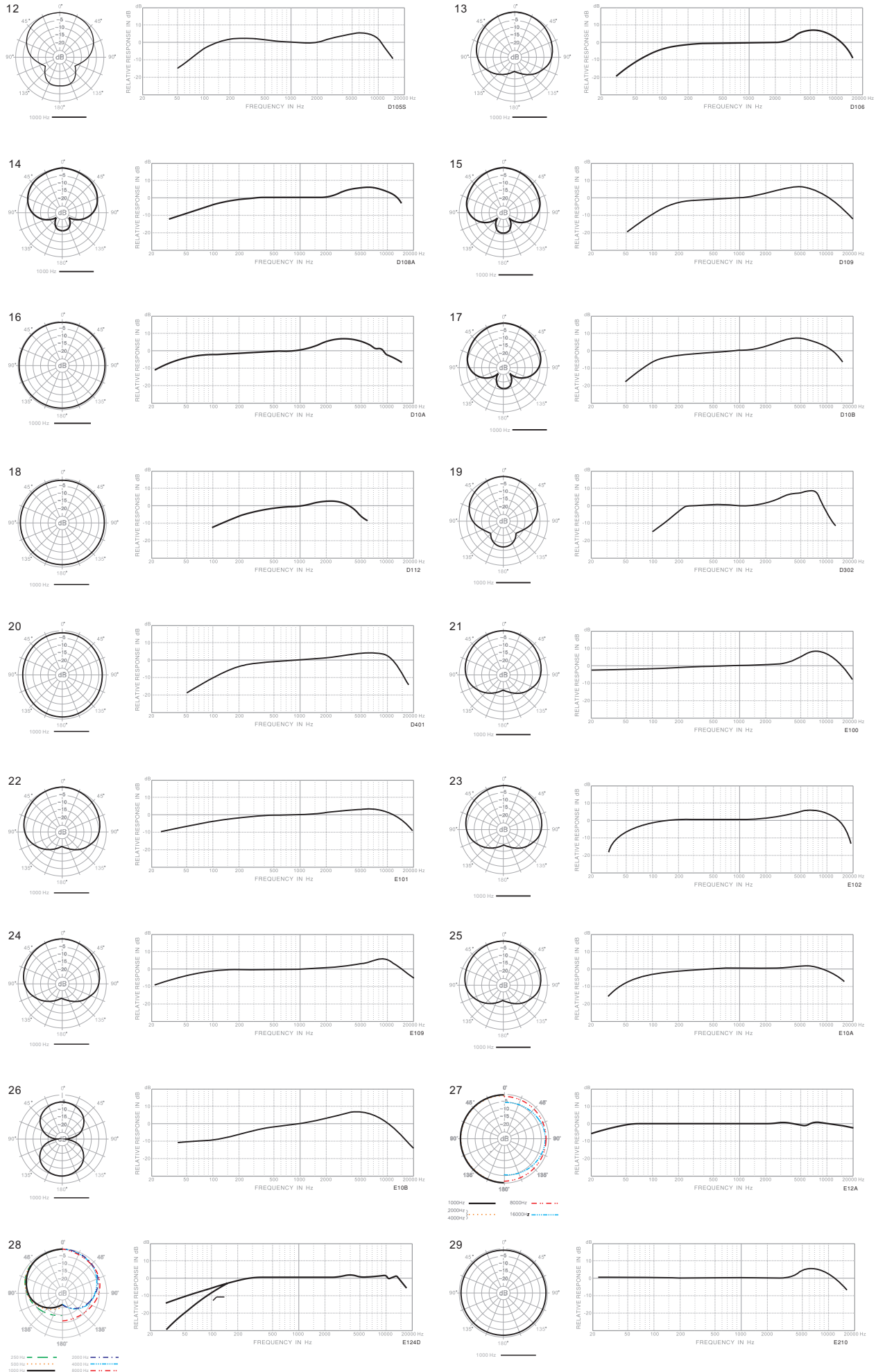

Charts and specifications 3

- 30 E302
- 31 E303
- 32 E304
- 33 E306
- 34 E321
- 35 E322/L/M
- 36 E323
- 37 E324
- 38 E522B
- 39 E523D
- 40 E524D
- 41 E531B
- 42 ECM888B
- 43 ECM999
- 44 ECO88
- 45 ECOA
- 46 FH12
- 47 FI10
- 48 FK2
- 49 FS6
- 50 FT4
- 51 HI10
- 52 HO8
- 53 PRA116B
- 54 PRA118S/L
- 55 PRA20
- 56 PRA218A
- 57 PRA218B
- 58 PRA228A
- 59 PRA268B
- 60 PRA288A
- 61 PRA30
- 62 PRA318S/L

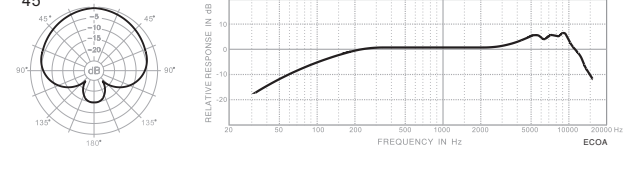
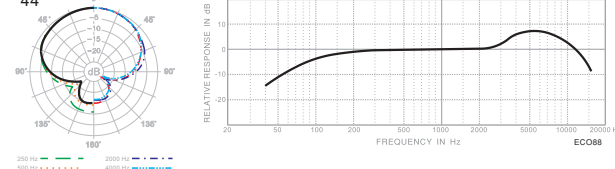
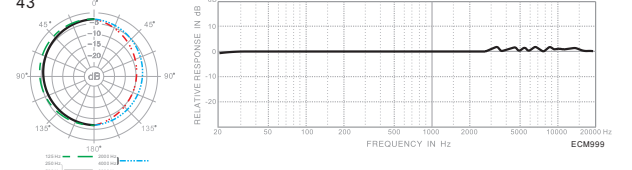
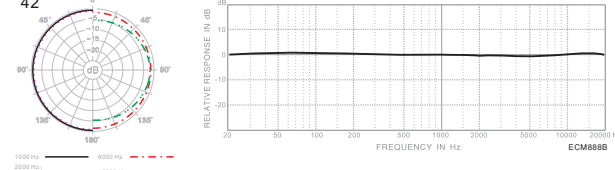
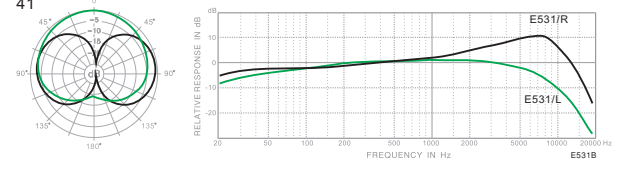
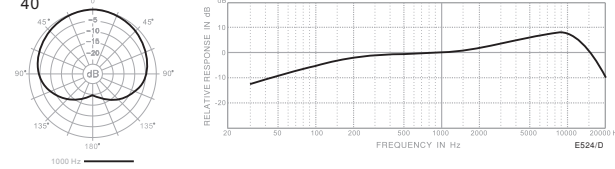
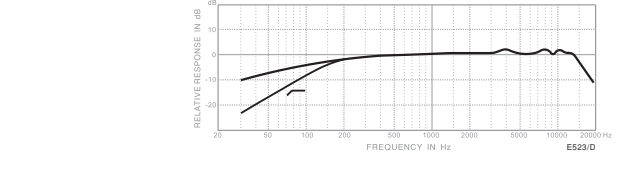
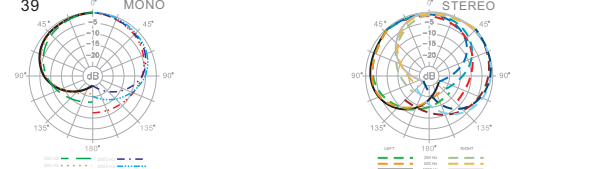
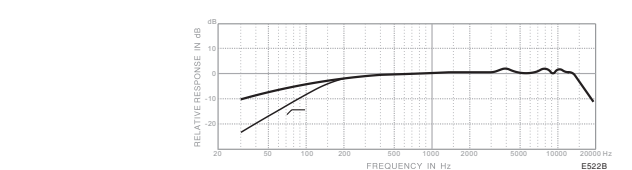
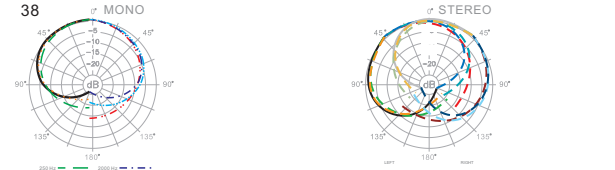
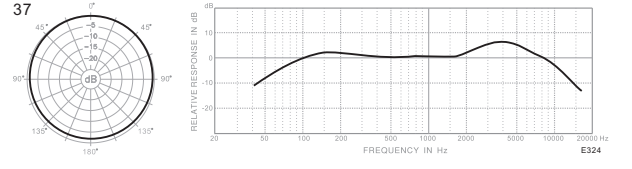
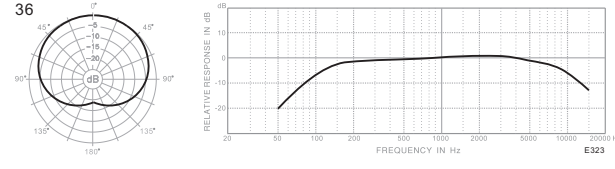
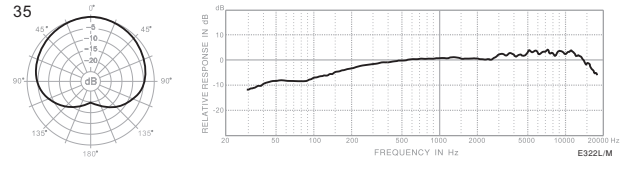
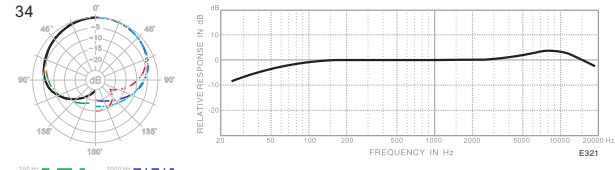
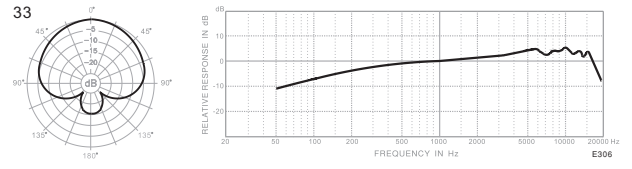
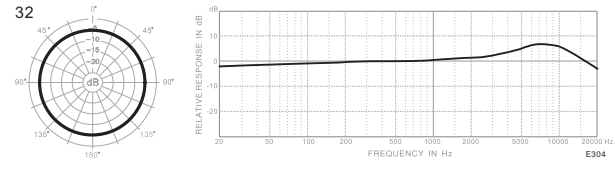
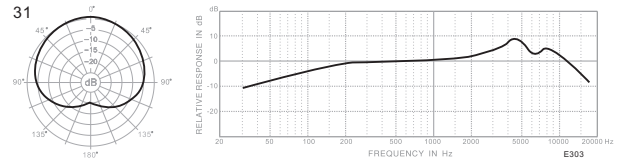
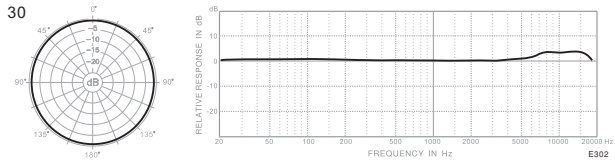

Charts and specifications 4

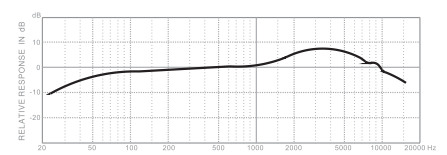
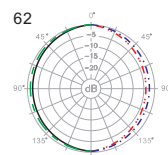
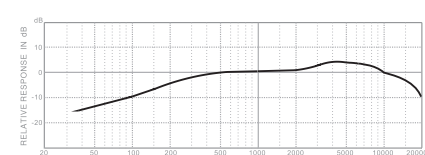
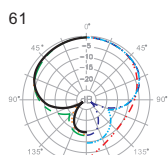
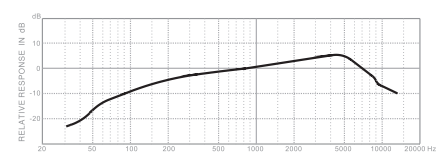
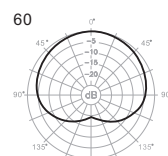
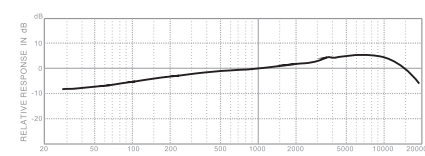
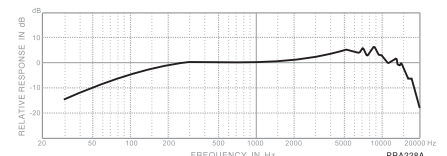
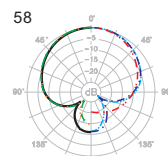
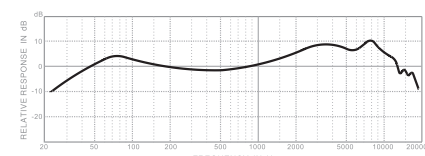
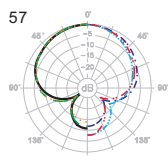
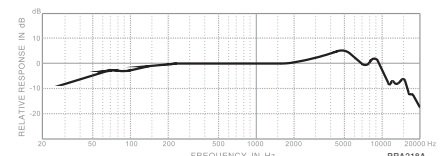
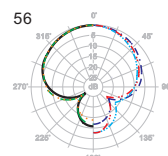
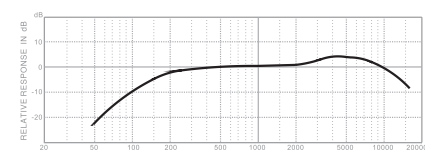
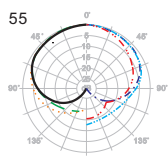
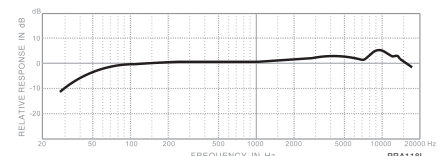
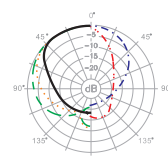
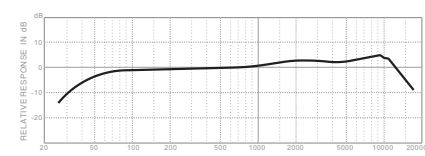
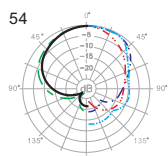
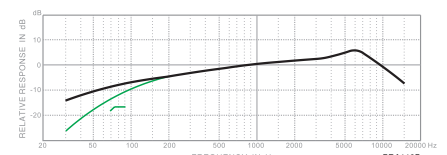
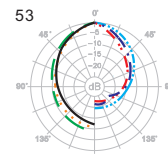
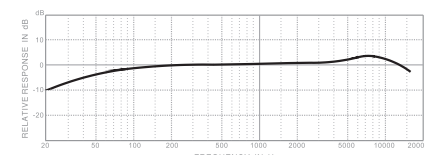
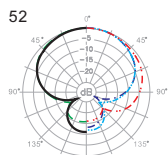
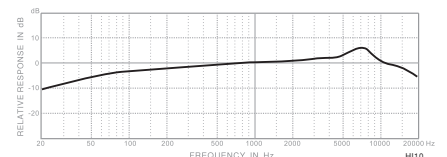
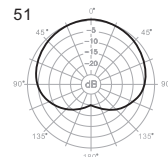
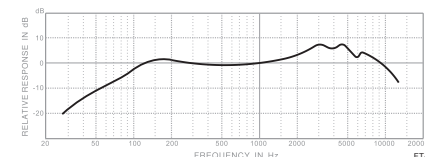
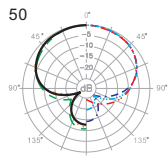
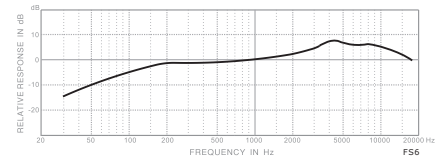
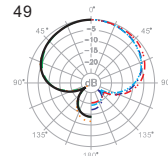
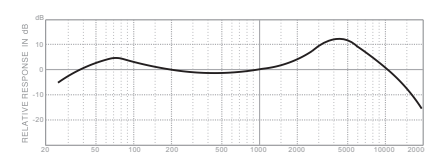
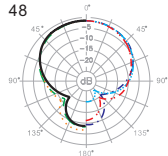
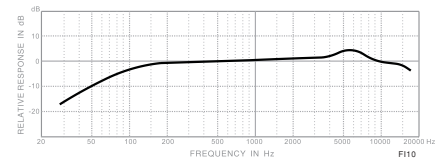
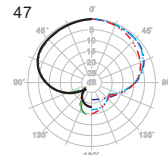
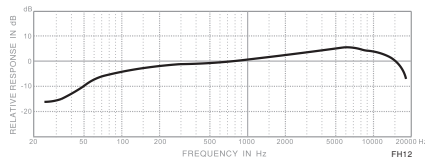
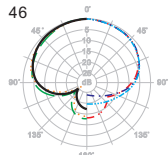

Charts and specifications 5

- 63 PRA383
- 64 PRA418
- 65 PRA428
- 66 PRA448
- 67 PRA518
- 68 PRA52
- 69 PRA528
- 70 PRA528DS
- 71 PRA535NC
- 72 PRA538
- 73 PRA618M
- 74 PRA628
- 75 PRA638
- 76 PRAC
- 77 PRAD
- 78 PRO218A
- 79 PRO228A
- 80 PRO238C
- 81 PRO248
- 82 PRO258
- 83 PRO268B
- 84 R102
- 85 S125
- 86 S241U3
- 87 TOP248
- 88 TOP258
- 89 WH5
- 90 WO518B
- 91 WU518B

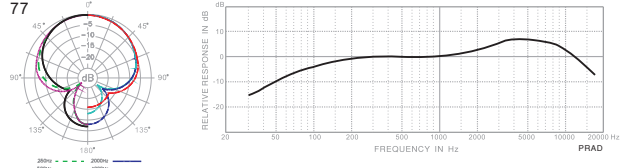
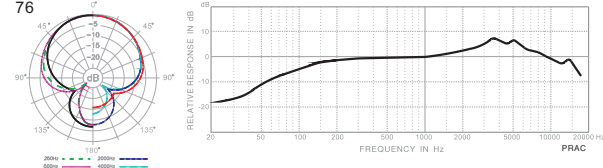
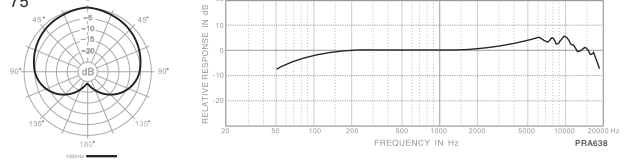
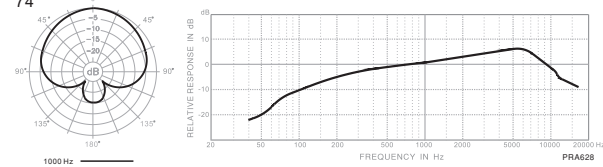
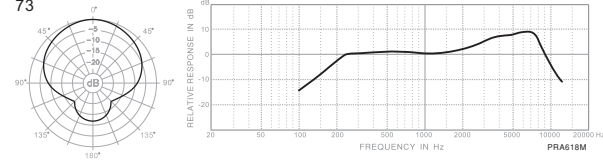
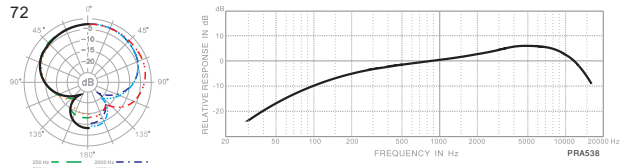
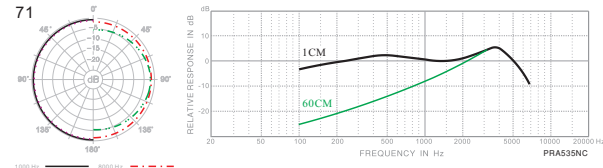
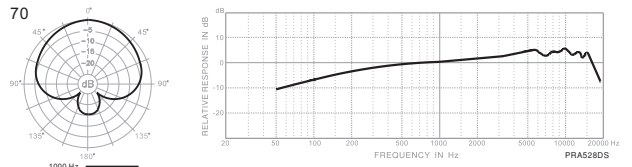
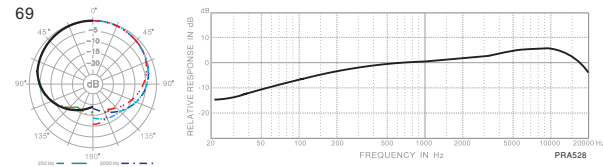
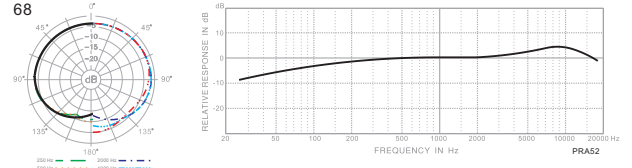
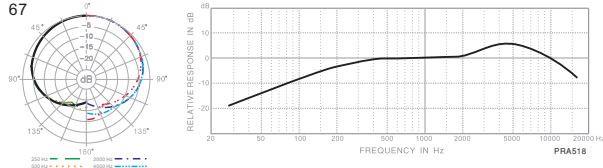
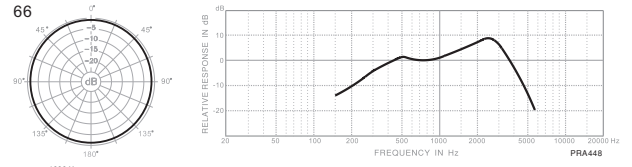
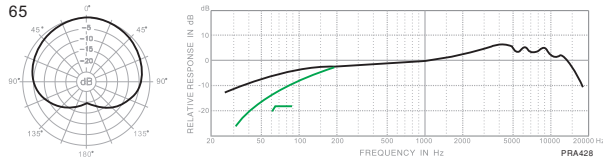
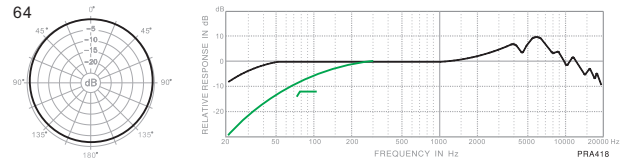
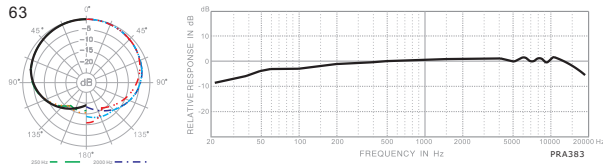

Charts and specifications 6

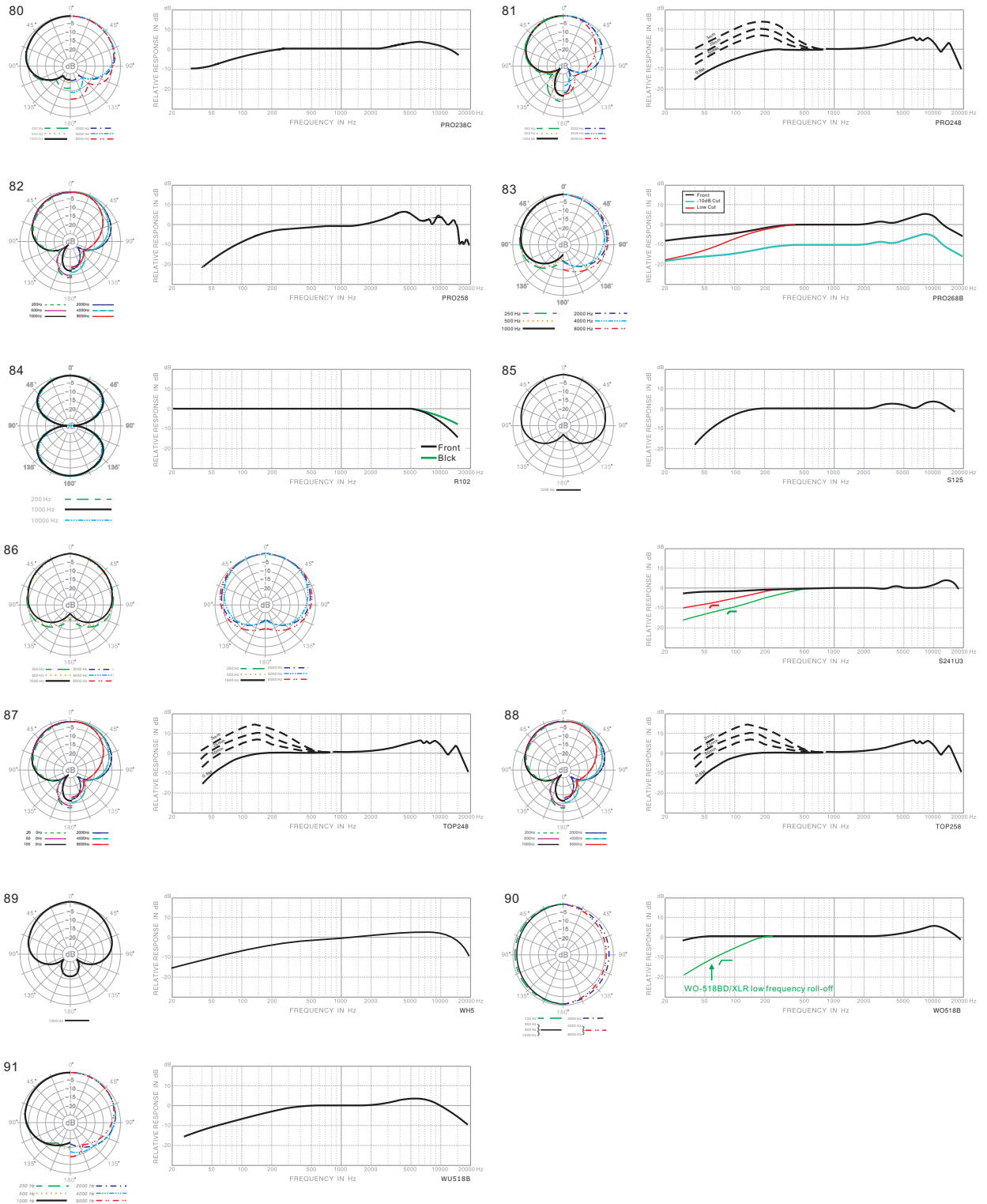

Model	Transducer		Acoustic	Specialties	Polar	Frequency Response		Built-in Filter	PAD	Sensitivity @ 1 Pa	Impedance	Min. Load
	Type	Dimension				LF	HF					
CMH8A	Condenser	1"	Pressure Gradient		Cardioid	30Hz	20KHz	100Hz, Internal	NA	-34dBV	200Ω	1KΩ
CMH8AH	Condenser	1"	Pressure Gradient		Cardioid	30Hz	20KHz	100Hz, Internal	NA	-34dBV	200Ω	1KΩ
CMH8B	Condenser	1"	Pressure Gradient		Cardioid	30Hz	20KHz	100Hz	-10dB	-34dBV	200Ω	1KΩ
CMH8BH	Condenser	1"	Pressure Gradient		Cardioid	30Hz	20KHz	100Hz	-10dB	-34dBV	200Ω	1KΩ
CMH8C	Condenser	1"	Pressure Gradient	Dual Capsule	Variable, 3	30Hz	20KHz	100Hz	-10dB	-30.5/-35.4dBV	200Ω	1KΩ
CMH8CH	Condenser	1"	Pressure Gradient	Dual Capsule	Variable, 3	30Hz	20KHz	100Hz	-10dB	-30.5/-35.4dBV	200Ω	1KΩ
CMH8D	Condenser	1"	Pressure Gradient	Dual Capsule, Vacuum Tube	Variable, 2	30Hz	20KHz	100Hz	NA	-28/-32dBV	200Ω	1KΩ
CMH8E	Condenser	1"	Pressure Gradient	Axial	Cardioid	30Hz	20KHz	80Hz, 100Hz	-10dB	-38.4dBV	200Ω	1KΩ
CMH8G	Condenser	1"	Pressure Gradient	Dual Capsule, Vacuum Tube	Variable, 9, Remote	30Hz	20KHz	NA	NA	-34dBV	200Ω	1KΩ
CMH8K	Electret Condenser	16mm	Pressure, Pressure Gradient	Exchangeable, 3 capsules	Omni, Cardioid, Super cardioid	40Hz	20KHz	NA	NA	-40dBV	200Ω	1KΩ
D103	Dynamic		Pressure Gradient		Super Cardioid	60Hz	16KHz	NA	NA	-52dBV	500Ω	1KΩ
D105S	Dynamic		Pressure Gradient		Super Cardioid	30Hz	12.5KHz	NA	NA	-53dBV	500Ω	1KΩ
D106	Dynamic		Pressure Gradient		Cardioid	70Hz	12KHz	NA	NA	-53dBV	500Ω	1KΩ
D108A	Dynamic		Pressure Gradient		Super Cardioid	50Hz	16KHz	NA	NA	-55dBV	250Ω	1KΩ
D109	Dynamic		Pressure Gradient	Hi-Z	Super Cardioid	80Hz	15KHz	NA	NA	TBA	10KΩ	100KΩ
D10A	Dynamic		Pressure		Omni	85Hz	12.5KHz	NA	NA	TBA	1KΩ	2KΩ
D10B	Dynamic		Pressure Gradient		Super Cardioid	60Hz	16KHz	NA	NA	TBA	500Ω	1KΩ
D112	Dynamic		Pressure	Hi-Z	Omni	100Hz	6KHz	NA	NA	-48dBV	10KΩ	100KΩ
D302	Dynamic		Pressure Gradient	Gooseneck	Super Cardioid	100Hz	10KHz	NA	NA	-56dBV	500Ω	1KΩ
D401	Dynamic		Pressure		Omni	80Hz	15KHz	NA	NA	TBA	500Ω	1KΩ
E100	Electret Condenser	14mm	Pressure Gradient	Kick boundary	Cardioid	60Hz	16KHz	NA	NA	-60dBV	600Ω	1KΩ
E101	Electret Condenser	9.7mm	Pressure Gradient	Acoustic guitar	Cardioid	50Hz	18KHz	NA	NA	-40dBV	200Ω	1KΩ
E102	Electret Condenser	6mm	Pressure Gradient		Cardioid	60Hz	15KHz	NA	NA	-48dBV	200Ω	1KΩ
E109	Electret Condenser	16mm	Pressure Gradient		Cardioid	40Hz	20KHz	NA	NA	-40dBV	200Ω	1KΩ
E10A	Electret Condenser	9.7mm	Pressure Gradient	Wearing	Cardioid	50Hz	15KHz	NA	NA	-44dBV	200Ω	1KΩ
E10B	Electret Condenser	9.7mm	Pressure Gradient	Wearing	Fig-8	50Hz	15KHz	NA	NA	-42dBV	200Ω	1KΩ
E124D	Electret Condenser	9.7mm	Pressure Gradient		Cardioid	40Hz	18KHz	NA	NA	-50dBV	600Ω	1KΩ
E210	Electret Condenser	9.7mm	Pressure		Omni	30Hz	20KHz	NA	NA	-42dBV	200Ω	1KΩ
E302	Electret Condenser	6mm	Pressure	Measurement	Omni	20Hz	20KHz	NA	NA	-43dBV	800Ω	1KΩ
E303	Electret Condenser	9.7mm	Pressure Gradient	Boundary	Cardioid	30Hz	18KHz	NA	NA	-39dBV	600Ω	1KΩ
E304	Electret Condenser	9.7mm	Pressure	Boundary	Omni	20Hz	18KHz	NA	NA	-39dBV	600Ω	1KΩ
E306	Electret Condenser	9.7mm	Pressure Gradient	Gooseneck	Cardioid	60Hz	15KHz	NA	NA	-36dBV	200Ω	1KΩ
E321	Electret Condenser	16mm	Pressure Gradient	Gooseneck	Cardioid	20Hz	18KHz	NA	NA	-40dBV	600Ω	1KΩ
E322	Electret Condenser	9.7mm	Pressure Gradient	Gooseneck	Cardioid	40Hz	20KHz	NA	NA	-40dBV	600Ω	1KΩ
E323	Electret Condenser	9.7mm	Pressure Gradient	Flush mount	Cardioid	60Hz	14KHz	NA	NA	-34dBV	200Ω	1KΩ
E324	Electret Condenser	9.7mm	Pressure	Flush mount	Omni	60Hz	14KHz	NA	NA	-30dBV	200Ω	1KΩ
E522B	Electret Condenser	XY Stereo	Pressure Gradient	XY Stereo	Cardioid	30Hz	20KHz	100Hz, Internal	NA	-53dBV	1KΩ	2KΩ
E523D	Electret Condenser	9.7mm	Pressure Gradient	XY Stereo	Cardioid	30Hz	20KHz	100Hz	NA	-47dBV	200Ω	1KΩ
E524D	Electret Condenser	16mm	Pressure Gradient	XY Stereo	Cardioid	20Hz	20KHz	NA	NA	-48dBV	200Ω	1KΩ
E531B	Electret Condenser	MS Stereo	Pressure Gradient	90° or 120°	Cardioid / fig-8	100Hz	15KHz	NA	NA	-45dBV	1KΩ	2KΩ
ECM888B	Electret Condenser	6mm	Pressure	Measurement	Omni	20Hz	20KHz	NA	NA	-43dBV	800Ω	3KΩ
ECM999	Electret Condenser	6mm	Pressure	Measurement	Omni	20Hz	20KHz	NA	NA	-37dBV	200Ω	1KΩ
ECO88	Dynamic		Pressure Gradient		Super Cardioid	80Hz	12KHz	NA	NA	-53dBV	500Ω	1KΩ
EOA	Dynamic		Pressure Gradient		Cardioid	70Hz	14KHz	NA	NA	-53dBV	500Ω	1KΩ
FH12	Dynamic		Pressure Gradient		Super Cardioid	50Hz	16KHz	NA	NA	-56dBV	250Ω	1KΩ
FI10	Dynamic		Pressure Gradient		Super Cardioid	50Hz	18KHz	NA	NA	-56dBV	250Ω	1KΩ
FK2	Dynamic		Pressure Gradient		Super Cardioid	30Hz	10KHz	NA	NA	-62dBV	200Ω	1KΩ
FS6	Dynamic		Pressure Gradient		Super Cardioid	50Hz	16KHz	NA	NA	-55dBV	200Ω	1KΩ
FT4	Dynamic		Pressure Gradient		Super Cardioid	20Hz	12.5KHz	NA	NA	-55dBV	200Ω	1KΩ
HI10	Electret Condenser	14mm	Pressure Gradient		Cardioid	50Hz	18KHz	NA	NA	-38dBV	200Ω	1KΩ
HO8	Electret Condenser	14mm	Pressure Gradient		Super Cardioid	40Hz	18KHz	NA	NA	-33dBV	200Ω	1KΩ
PRA116B	Electret Condenser	9.7mm	Interference Tube		Shot Gun	50Hz	14KHz	NA	NA	-38dBV	600Ω	1KΩ
PRA118S/L	Electret Condenser	14mm	Interference Tube		Shot Gun	30Hz	16KHz	NA	NA	-33/-35dBV	200Ω	1KΩ
PRA20	Dynamic		Pressure Gradient		Cardioid	50Hz	15KHz	NA	NA	-67dBV	200Ω	1KΩ
PRA218A	Dynamic		Pressure Gradient		Super Cardioid	20Hz	12.5KHz	NA	NA	-53dBV	500Ω	1KΩ
PRA218B	Dynamic		Pressure Gradient		Super Cardioid	30Hz	10KHz	NA	NA	-63dBV	200Ω	1KΩ
PRA228A	Dynamic		Pressure Gradient		Super Cardioid	50Hz	16KHz	NA	NA	-53dBV	500Ω	1KΩ
PRA268A	Dynamic		Pressure Gradient		Super Cardioid	50Hz	16KHz	NA	NA	-43dBV	200Ω	1KΩ
PRA288A	Dynamic		Pressure Gradient		Super Cardioid	80Hz	20KHz	NA	NA	-56dBV	500Ω	1KΩ
PRA30	Electret Condenser		Pressure Gradient		Super Cardioid	50Hz	15KHz	NA	NA	-40dBV	200Ω	1KΩ
PRA318S/L	Dynamic		Pressure		Omni	50Hz	15KHz	NA	NA	-74dBV	500Ω	1KΩ
PRA383	Electret Condenser	9.7mm	Pressure Gradient		Cardioid	40Hz	18KHz	NA	NA	-42dBV	200Ω	1KΩ
PRA418	Electret Condenser	9.7mm	Pressure	Boundary	Omni	30Hz	20KHz	NA	NA	-44/-42dBV	270/200Ω	1KΩ
PRA428	Electret Condenser	9.7mm	Pressure Gradient	Boundary	Cardioid	30Hz	20KHz	NA	NA	-45/-44dBV	270/200Ω	1KΩ
PRA448	Dynamic		Pressure		Omni	150Hz	4.5KHz	NA	NA	-51dBV	500Ω	1KΩ
PRA518	Electret Condenser	6mm	Pressure Gradient	Gooseneck	Cardioid	50Hz	16KHz	NA	NA	-39dBV	200Ω	1KΩ
PRA52	Electret Condenser	9.7mm	Pressure Gradient		Cardioid	50Hz	16KHz	NA	NA	-39dBV	200Ω	1KΩ
PRA52B	Electret Condenser	9.7mm	Pressure Gradient	Gooseneck	Cardioid	50Hz	16KHz	NA	NA	-39dBV	200Ω	1KΩ
PRA528DS	Electret Condenser	9.7mm	Pressure Gradient	Gooseneck	Cardioid	50Hz	16KHz	NA	NA	-36dBV	200/600Ω	1KΩ
PRA535NC	Dynamic		Pressure	Noise Cancelling	Omni	300Hz	5KHz	NA	NA	-68dBV	200Ω	1KΩ
PRA538	Dynamic		Pressure Gradient	Gooseneck	Super Cardioid	100Hz	15KHz	NA	NA	-58dBV	500Ω	1KΩ
PRA618	Dynamic		Pressure Gradient	Gooseneck	Super Cardioid	100Hz	10KHz	NA	NA	-56dBV	500Ω	1KΩ
PRA628	Electret Condenser		Pressure Gradient		Cardioid	80Hz	16KHz	NA	NA	-56dBV	500Ω	1KΩ
PRA638	Electret Condenser	16mm	Pressure Gradient		Cardioid	50Hz	20KHz	NA	NA	-36dBV	200Ω	1KΩ
PRAC	Dynamic		Pressure Gradient		Cardioid	50Hz	16KHz	NA	NA	-54dBV	200Ω	1KΩ
PRAD	Dynamic		Pressure Gradient		Cardioid	50Hz	16KHz	NA	NA	-54dBV	200Ω	1KΩ
PRO218A	Dynamic		Pressure Gradient		Super Cardioid	20Hz	10KHz	NA	NA	-64dBV	45Ω	1KΩ
PRO228A	Dynamic		Pressure Gradient		Super Cardioid	50Hz	16KHz	NA	NA	-54dBV	300Ω	1KΩ
PRO238C	Electret Condenser		Pressure Gradient		Super Cardioid	50Hz	16KHz	NA	NA	-44dBV	200Ω	1KΩ
PRO248, TOP248	Dynamic		Pressure Gradient		Super Cardioid	50Hz	16KHz	NA	NA	-54dBV	300Ω	1KΩ
PRO258, TOP258	Dynamic		Pressure Gradient		Super Cardioid	50Hz	16KHz	NA	NA	-54dBV	300Ω	1KΩ
PRO268A	Electret Condenser		Pressure Gradient		Super Cardioid	50Hz	20KHz	NA	NA	-45dBV	200Ω	1KΩ
R102	Ribbon	2.5µm	Pressure Gradient	Active Ribbon	Figure 8	25Hz	15KHz	NA	NA	-39dBV	250Ω	1KΩ
S125	Condenser	1/2"	Pressure Gradient		Cardioid	20Hz	20KHz	TBA	-10dB	-45dBV	50Ω	1KΩ
S241U3	Condenser	1/2"	Pressure Gradient		Cardioid	20Hz	20KHz	75Hz, 150Hz	-10, -20dB	-35dBV	200Ω	1KΩ
WH5	Dynamic		Pressure Gradient	Trilogy capsules	Super Cardioid	50Hz	16KHz	NA	NA	-54dBV	300Ω	1KΩ
W0518	Electret Condenser	6mm	Pressure		Omni	20Hz	20KHz	NA	NA	-45dBV	200Ω	1KΩ
WU518	Electret Condenser	6mm	Pressure Gradient		Cardioid	60Hz	15KHz	NA	NA	-48dBV	200Ω	1KΩ

Model	Equivalent Noise SPL	Maximum SPL	Dynamic Range	Power	Consumption	Connector	Dimension in mm	Weight gram	Switch Version	YA-1 adapter Included?
CMH8A	18dB	132dB	114dB	P48	2.7mA	XLR3M, Gold	Ø54 x 200	550		Y
CMH8AH	18dB	132dB	114dB	P48	2.7mA	XLR3M, Gold	Ø54 x 200	550		Y
CMH8B	18dB	142dB	124dB	P48	2.7mA	XLR3M, Gold	Ø54 x 200	550		Y
CMH8BH	18dB	142dB	124dB	P48	2.7mA	XLR3M, Gold	Ø54 x 200	550		Y
CMH8C	14/18dB	138/142dB	124dB	P48	4mA	XLR3M, Gold	Ø54 x 200	565		Y
CMH8CH	14/18dB	138/142dB	124dB	P48	4mA	XLR3M, Gold	Ø54 x 200	567		Y
CMH8D	14/18dB	142/148dB	128/130dB	PS1, proprietary, supplied	4mA	XLR7M, Cable Included	Ø54 x 200	550		Y
CMH8E	18dB	145dB	127dB	P48	2.7mA	3P XLR, Gold	Ø54 x 200	550		Y
CMH8G	18dB	132dB	114dB	PS3, proprietary supplied	2.7mA	XLR7M, Cable Included	Ø54 x 200	550		Y
CMH8K	22dB	134dB	112dB	P48	3.5mA	3P XLR, Gold	Ø20 x 150	170		Y
D103						XLR3M, Gold	Ø58 x 140	350		
D105S						XLR3M	Ø45 x 180	240	All	Y
D106						1/4" plug	Ø54 x 208	230	All	
D108A						XLR3M, Gold	Ø54 x 180	350	All	Y
D109						XLR3M, Gold	Ø43 x 123	185	All	
D10A						3.5mm plug	Ø36 x 137	95		
D10B						XLR3M	Ø41.5 x 145.3	250		Y
D112						1/4" plug	Ø63 x 80	650		
D302						wire out	Ø30 x 295	150		
D401S						XLR3M	Ø54 x 180	300	All	Y
E100	24dB	149dB	125dB	P48	4mA	XLR3M	Ø84 x 23.5	270		
E101	24dB	126dB	102dB	P9-48	4mA	XLR3M		20		
E102	26dB	132dB	106dB	P9-48	4mA	XLR3M		150		Y
E109	22dB	134dB	116dB	P48	3.5mA	XLR3M	Ø20 x 112	120		Y
E10A	23dB	139dB	116dB	P9-48		TA3F / XLR3M		18		
E10B	23dB	137dB	114dB	P9-48		TA3F / XLR3M		20		
E124D	20dB	131/127dB	111/107dB	P48, Battery 1.5V	2mA	XLR3M	Ø31(24) x 205	300		Y
E210		118dB		1.5~-5V bias		3.5mm plug		20		
E302	22dB	128dB	106dB	1.5~-5V bias		3.5mm plug		90		
E303	24dB	127dB	103dB	P9-48	4mA	TA3M / XLR3M	Ø84 x 22.5	240		
E304	24dB	127dB	103dB	P9-48	4mA	TA3M / XLR3M	Ø84 x 23.5	230		
E306	124dB	124dB		P9-48	4mA	wire out	Ø30 x 295	150		
E321	24dB	127dB	103dB	P9-48	4mA	XLR3M	Ø20 x 45	200		
E322	24dB	127dB	103dB	P9-48	4mA	XLR3M	Ø20 x 45 / 60	160/220		
E323	26dB	132dB	106dB	P9-48	2mA	XLR3M	Ø22 (34) x 72	100		
E324	26dB	132dB	106dB	P9-48	2mA	XLR3M	Ø22 (34) x 72	100		
E522B	20dB	120dB	100dB	Battery 1.5V		XLR3M stereo	64 x 38 Head, Ø23.5 x 220	330	All	Y
E523D	24dB	126dB	102dB	P48, Battery 1.5V	2mA	XLR5M, Cable Included	64 x 38 Head, Ø23.5 x 220	340		Y
E524D	24dB	126dB	102dB	P9-48, Battery 1.5V	2mA	XLR5M	78 Width, Ø23.5 x 216	380	All	Y
E531B	25dB	110dB	85dB	Battery 1.5V	4mA	3.5mm st plug		110	All	Y
ECM888B	26dB	132dB	106dB	4LR44, 6V	0.5mA	XLR3M	Ø21 x 170	150		Y
ECM999	26dB	132dB	106dB	P9-48	2mA	XLR3M	Ø21 x 193	150		Y
EC088						XLR3M	Ø54 x 180	250	All	
EC0A						XLR3M	Ø54 x 180	200	All	
FH12		134dB				XLR3M	Ø49 x 177	400	Yes	Y
FI10		134dB				XLR3M	Ø49 x 173	395		Y
FK2		147dB				XLR3M	Ø51 x 115	210		Y
FS6		140dB				XLR3M	Ø43 x 101	130		Y
FT4		150dB				XLR3M	Ø43 x 101	130		Y
HI10		134dB		P9-48	5mA	XLR3M	Ø21 x 94	120		Y
HO8		136dB		P48	3mA	XLR3M	Ø53 x 170	320		Y
PRA116B	20dB	116dB	96dB	4LR44, 6V battery	TBA	XLR3M	Ø34 x 180(230)	110/140		Y
PRA118S/L	20dB	134dB	114dB	P48		XLR3M	Ø21 x 340(540)	200/250		Y
PRA20		136dB				XLR3M		23		
PRA218A		134dB				XLR3M	Ø43 x 120	210		Y
PRA218B		144dB				XLR3M	Ø58 x 140	350		Y
PRA228A		134dB				XLR3M	Ø42 x 110	180		Y
PRA268A	25dB	137dB	112dB	P9-48		XLR3M	Ø29 x 165	180		Y
PRA288A		140dB				XLR3M	Ø29 x 107	110		Y
PRA30	24dB	136dB	112dB	P9-48		TA3F / XLR3M		20		
PRA318S/L						XLR3M	Ø34 x 180/230	110/140		Y
PRA383	23dB	137dB	114dB	PS418S/D	3.5mA	TA4F, TA3F	Ø20 x 150	160		
PRA418		132/118dB		PS418S/D		TA3F	Ø65 x 15	80		
PRA428		134/120dB		PS418S/D		TA3F	64 x 92 x 16	110		
PRA448						pin out	114.5 x 70 x 29	85		
PRA518	26dB	130dB	104dB	P9-48	3mA	XLR3M	Ø8 x 31/45/60	130-165		
PRA52	26dB	132dB	106dB	P9-48	3mA	XLR3M	Ø12 x 27	180		
PRA528	26dB	132dB	106dB	P9-48	3mA	XLR3M	Ø20 x 41/47/56/62	150-220		
PRA528DS		124/114dB		P12-48, Battery 1.5V	3/1.2mA	XLR3M		1000		
PRA535NC						wire out	67 x 94 x 50	250 / 20		
PRA538						wire out	Ø32 x 310/480	500/550		
PRA618		140dB				XLR3M	Ø30 x 450	170		
PRA628		144dB				XLR3M	Ø60 x 130 x 35	210		Y
PRA638		146dB		P9-48		XLR3M	Ø60 x 130 x 35	190		Y
PRAC		140dB				XLR3M	Ø53 x 180	363	All	Y
PRAD		140dB				XLR3M	Ø53 x 180	370		Y
PRO218A		170dB				XLR3M, Gold	Ø58 x 140	350		Y
PRO228A		150dB				XLR3M, Gold	Ø43 x 123	185		Y
PRO238C				P48	3mA	XLR3M	Ø45 x 180	240		Y
PRO248, TOP248	26dB	130dB	104dB	P48	3mA	XLR3M, Gold	Ø54 x 180	343	Yes	Y
PRO258, TOP258						XLR3M, Gold	Ø54 x 180	343		Y
PRO268A	25dB	140dB	115dB	P48	2mA	XLR3M, Gold	Ø29 x 238	280		Y
R102	20dB	> 140dB	> 120dB	P48	4mA	3P XLR, Gold	57 x 27 x 195	500		Y
S125	18dB	148dB	130dB	P48	3.5mA	XLR3M, Gold	TBA	TBA		Y
S241U3	16dB	143dB	127dB	P48	3mA	XLR3M, Gold	Ø22 x 155	220		Y
WH5						XLR3M	TBA	500	All	Y
WO518		132dB		P9-48		XLR3M	Ø8 x 12	100		
WU518		132dB		P9-48		XLR3M	Ø8 x 12	100		

Which microphone for you?

Facing variety of microphones, how to find the right one for your application? This question, could be put this way: "Which mic is the best?" Yes, if the answer is that easy, maybe there is only one microphone in the world to fulfill all demands. There are reasons of all kinds of demands, the answer varies accordingly.

Which type of transducer?



Dynamics

Durable and simple structure, operates in all kinds of environments. A good dynamic microphone is capable to operate at very high sound pressure level without distortion. Due to structure limit, dynamics cannot be built as small as condenser, but dynamics doesn't require power to operate.



Condenser

Extremely light weight diaphragm, very sensitive to sound. Very small versions available for hiding applications. High performance condenser microphones are regarded as standard equipment of recording studios for extreme detail capturing. Operates with power, such as phantom or battery.

Which kind of directivity?



Omnidirectional

Equal sensitivity to all direction, so that the microphone doesn't need to pointing toward the sound source. Low handling and wind noise. Welcome by news gathering, and music recording applications.



Cardioid

Picks up most signal on axis. Rejects side and picks up least to the back. Suitable for live sound re-inforcement. Apparent proximity effect and most singer likes to take this bass boost advantages which is not good for speech.



Super Cardioid

Narrower than cardioid pattern. Suitable for multiple microphone setup. Least sensitive angle pointing toward side to rear where most stage monitors are located. Same proximity effect as cardioid microphone.



Figure 8, bi-directional

Equal sensitive to both ends, and rejects the sides. Good to noisy environment to reject distant noise and low frequency. Also a good choice for stereo recordings, such as Blumlein. Typical pressure gradient characteristic.



Shotgun

Based on interference tube theory, to achieve highest axial signal pick-up and rejects off-axis sound as much as possible. Due to poor wind noise rejection, suitable wind screen shall be used at outdoor.

About Frequency Response

Flat

Suitable for working at controlled environment, or for acoustic measurements. Although people pursuit flatness, but for none-professionals, it is a challenge to makes it works as expectation.

Popular curve response

Based on years of practical experience of pro users. There are curves to be build for various applications, so that it is very simple to use the microphone for the purpose. Limiting bandwidth, and emphasizing are typical skill.

Variable response

Incorporating switchable filters to eliminates interference, such as sub-sonic filter to cut air-conditioner and floor vibrations. And allows full flat when used in controlled environment.

Goang Fann manufacturing for Superlux as well as name brands. Years of OEM experience based on faithful concept.

Superlux GDC is the developing mile stone of GF group at Shanghai. 8 buildings in a 35,000 square meters land space will be ready to operate in August 2007. Automated and computerized global distribution center will serve international customers with more efficient and rapid operation.

OEM, ODM

Original Engineering 'n' Design

旭广企业发展（上海）有限公司

厂区鸟瞰图



上海大同一钢建筑设计研究院有限公司

Goang Fann welcome OEM and ODM business for name brands and special contract order for customized products.

Our production capabilities based on own plastic injection, die-casting, CNC, all metal works, toolings, paintings, capsules assembly, cable wires fabricating, electronics productions, speaker driver assembly... from raw material to finish products.

ISO14001 certified system guarantee quality and environmental protection. ROHS production qualification meets the latest advanced requirement.

Please contact sales@tenlux.com. tw for OEM detail. We are more than happy to work with you to fulfill your project tasks.



Anechoic Chamber 1

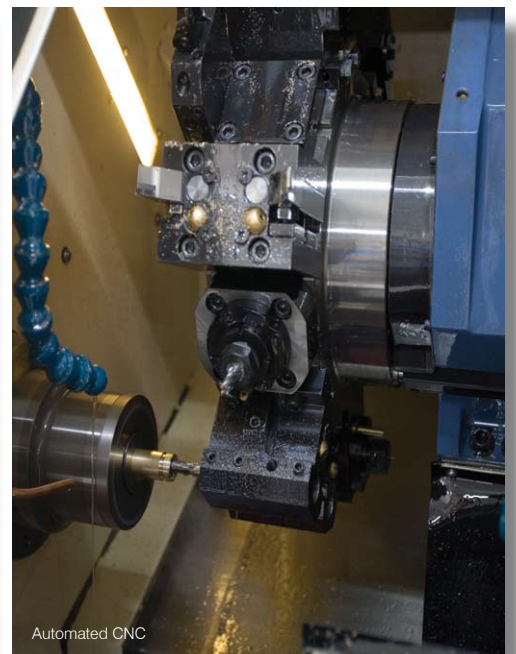

Automated CNC

Index

Model	Page	Model	Page	Model	Page	Model	Page
4U2SET	33	DMC03	38	ECM999	33	HM40C	36
AM100S24102AO	6	DRK681	21	ECO88S	13	HM42	36
AT0	30	DRKA3C2	21	ECOA	13	HM43	35
AT1	30	DRKA5C2	21	FH12	13	HM48B	55
C2	37	DRKB5C2MKII	21	FH12S	13	HM501	55
CFI0.3PP	41	DRKF5H3	21	FI10	13	HM502	55
CFI0.6PP	41	DRKK5C2	21	FK2	18	HM503	55
CFI0.9PP	41	DS002	35	FS6	19	HM54	36
CFI1.5PP	41	DS003	25	FT4	19	HM58B	55
CFI3PP	41	DS003	35	GM13D	24	HM6	54
CFI4.5PP	41	DS01	54	GM13G	24	HM7	37
CFI6PP	41	DS011	54	GT2B	25	HM9	36
CFI9PP	41	DS70	59	GT6F	25	HMC660	43
CFM0.5FM	41	E100	18	HD330	43	HMC660E	43
CFM10FM	41	E101DXLR	17	HD440	49	HMC660X	43
CFM10FP	41	E101TQG	17	HD660	43	HMD660	43
CFM1FM	41	E102	18	HI10	19	HMD660E	43
CFM2.5FM	41	E105	51	HM10	36	HMD660X	43
CFM20FM	41	E108	51	HM101	36	H08	19
CFM5.0FM	41	E109	19	HM12A	38	LS718S	56
CFM5FP	41	E10ADXLR	15	HM12C	38	MA500	51
CFM7.5FP	41	E10ATQG	15	HM12CA	38	MA500/105	51
CMH8A	5	E10AXLR	15	HM12CB	38	MA500/108	51
CMH8AH	5	E10BDXLR	15	HM12D	38	MA500/10A	51
CMH8B	5	E10BTQG	15	HM12DA	38	MA500/210	51
CMH8BH	5	E10BXLRL	15	HM12DB	38	MA818	50
CMH8C	5	E124D	18	HM12DC	38	MA818/105	50
CMH8CH	5	E12ADXLR	15	HM12DD	38	MA818/106	50
CMH8D	5	E12ATQG	15	HM12E	38	MA818/108	50
CMH8E	9	E12AXLR	15	HM12F	38	MA818/10A	50
CMH8G	5	E210	49	HM15	37	MA818/210	50
CMH8KH	6	E302	49	HM18AG	55	MA818/535NC/P	50
CMH8KO	6	E303B	26	HM22	24	MA90	37
CMH8KU	6	E303W	26	HM23	24	MA91	55
CMH8KUHO	6	E304B	26	HM24	24	MS101	52
CP818	35	E304W	26	HM24C	24	MS101/BAG	52
CP828	35	E306	25	HM25	38	MS104/BAG	54
CP838	35	E321	25	HM26A	37	MS105/BAG	54
D1	54	E322LB	25	HM26B	37	MS107	52
D103	13	E322LW	25	HM26C	37	MS108E	53
D105S	27	E322MB	25	HM29	36	MS108E/BAG	53
D106	49	E322MW	25	HM30	36	MS128/BAG	52
D108A	13	E323B	27	HM31	36	MS131E/BAG	53
D109	13	E323W	27	HM31	37	MS141E/BAG	53
D10A	49	E324B	27	HM32	36	MS152E/BAG	53
D10B	17	E324W	27	HM35	36	MS153E/BAG	53
D112	17	E522B	49	HM35C	36	MS158/BAG	58
D302	25	E523D	9	HM37	36	MS200	54
D401S	27	E524D	6	HM38	36	MS300	52
DMC01	38	E531B	49	HM39	36	MSK-10BP	23
DMC02	38	ECM888B	33	HM40	36	MSK-10BX	23

Model	Page	Model	Page	Model	Page	Model	Page
MSK-124P	23	PRA638	18	SFI3PR	41	SPS410AB	56
MSK-124X	23	PRAC	13	SFI3RR	41	SPS410B	56
MSK-AP	23	PRAD	13	SFI4.5PP	41	SPS430L	57
MSK-AX	23	PRO218A	17	SFI4.5PR	41	SPS813	57
MTS004	54	PRO228A	17	SFI6PP	41	SPS823	57
MTS014	54	PRO238C	13	SFI6RR	41	SPS838	57
MTS024	54	PRO248	12	SFI7.5PR	41	SPS867A	57
PINK STICK	33	PRO248S	12	SFM0.5FM	41	SPS868	57
PRA116B	9	PRO258	12	SFM1.5FM	41	SPS878	57
PRA118L	9	PRO268B	17	SFM10FM	41	SPSK1	56
PRA118S	9	PS1	5	SFM10FP	41	SPSK2	56
PRA20TQG	15	PS2A	35	SFM2.5FM	41	TOP248	12
PRA20XLR	15	PS2B	35	SFM20FM	41	TOP248S	12
PRA218A	18	PS3	5	SFM5.0FM	41	TOP258	12
PRA218B	18	PS418D	35	SFM5FP	41	UDA28	30
PRA228A	19	PS418S	35	SFM7.5FM	41	UT2	29
PRA268A	19	R102	9	SFM7.5FP	41	UT2/10A	29
PRA288A	17	RK1	30	SFS0.9SP	41	UT2/10B	29
PRA30DXLR	15	RK2	30	SFS10PP	41	UT2/12A	29
PRA30TQG	15	RS908	59	SFS10SS	41	UT2/20	29
PRA30XLR	15	RS912	59	SFS15PP	41	UT2/30	29
PRA318L	9	RS916	59	SFS15SS	41	UT2/383	29
PRA318S	9	RS921	59	SFS20PP	41	UT2/518	29
PRA383DXLR	17	S02	39	SFS20SS	41	UT4/108A	29
PRA383TQG	17	S04	39	SFS3PP	41	UT4/125	29
PRA383XLR	17	S08F	39	SFS3SP	41	UT4/238C	29
PRA418	27	S09	39	SFS3SS	41	UT4/248	29
PRA428	27	S09F	39	SFS5PP	41	UT6	29
PRA448	27	S11	39	SFS5SS	41	UT62/10A	30
PRA448S	27	S12	39	SFS9SP	41	UT62/10B	30
PRA518AL	25	S125	6	SM112	46	UT62/12A	30
PRA518AM	25	S14	39	SM112F	46	UT62/20	30
PRA518AS	25	S15	39	SM115	46	UT62/30	30
PRA518BL	25	S241	6	SM115F	46	UT62/383	30
PRA518BM	25	S25	39	SM118S	45	UT62/O518B	30
PRA518M	25	S40	39	SM12	46	UT62G	30
PRA528BL	25	S65	39	SM12F	46	UT64/108A	30
PRA528BM	25	SA118S	47	SM15	46	UT64/125	30
PRA528CL	25	SA215S	47	SM15F	46	UT64/238C	30
PRA528CM	25	SA28	47	SM215	46	UT64/248	30
PRA528DS	25	SFI0.3PP	41	SMKH8A	5	WH5	13
PRA52B	26	SFI0.3RR	41	SMKH8B	5	W0518BDXLR	15
PRA52W	26	SFI0.6PP	41	SMKH8C	5	W0518BTQG	15
PRA535	27	SFI0.6RR	41	SMKH8K	6	W0518BXL	15
PRA535NC	27	SFI0.9PP	41	SN112A	45	WU518BDXLR	15
PRA538M	25	SFI0.9PR	41	SN112A	45	WU518BTQG	15
PRA538MS	25	SFI0.9RR	41	SN115A	45	WU518BXL	15
PRA538MS PTT	25	SFI1.5PP	41	SN115A	45	YA10	36
PRA538S	25	SFI1.5PR	41	SPA01	56		
PRA538SS	25	SFI1.5RR	41	SPS400	57		
PRA628	18	SFI3PP	41	SPS410A	56		

Note



Pictures Credits
Tammy Tung, Cover
Rick Chen, P.10, P.22
Xin-Hai Wang, P.14
Lawrence Liu, P.16
Annie Chang, P.19
Jay Wu, P.20
Wen-Hui Tsai, P.28
Alison Yeh, P.31
Lawrence Liu, Keith Lin, This page
Bing Wang, Back cover
Tony Ching, Photographer



Superlux[®]
Just Play It

www.superlux.com.tw

Taipei Office
Goang Fann Co., Ltd.
#7, 3F Alley 2, Lane 342
Fu-Der 1st Road, Xichih,
Taipei, Taiwan 22150
Tel: +886 (2) 2693-1323
Fax: +886 (2) 2694-8990
Email: sales@superlux.com.tw

Shanghai Office/Factory
Shanghai Goang Fann Ltd.
#2, 3F, Lane 1225, Tong-Pu Road,
Pu-Tor Dist., Shanghai, China,
200333
Tel: +86 (21) 5270-7600
Fax: +86 (21) 5270-7602
Email: sales@superlux.com.tw
03/07 ©2007 Goang Fann Co., Ltd.
Printed in Taiwan, 5K

Shengzhen Factory
Shengzhen Goang Fann Mfg., Ltd.
Shengzhen Bao-An Dist., Guan-Lan
Town, Jun-Zi-Bu Village China, 518100
Tel: +86 (755) 2816-1507
Fax: +86 (755) 2816-1006
Email: sales@tenlux.com.tw