



owner's manual

MIX.50  
MIX.60  
MIX.100  
MIX.120

# MIX-SERIES

ULTRA-COMPACT MIXERS

**TAPCO**<sup>®</sup>

TOTAL AUDIO PRODUCTION

**CAUTION AVIS**



RISK OF ELECTRIC SHOCK  
DO NOT OPEN  
RISQUE DE CHOC ELECTRIQUE  
NE PAS OUVRIR



**CAUTION: TO REDUCE THE RISK OF ELECTRIC SHOCK  
DO NOT REMOVE COVER (OR BACK)  
NO USER-SERVICEABLE PARTS INSIDE  
REFER SERVICING TO QUALIFIED PERSONNEL**

ATTENTION: POUR EVITER LES RISQUES DE CHOC  
ELECTRIQUE, NE PAS ENLEVER LE COUVERCLE. AUCUN  
ENTRETIEN DE PIECES INTERIEURES PAR L'USAGER. CONFIER  
L'ENTRETIEN AU PERSONNEL QUALIFIE.

AVIS: POUR EVITER LES RISQUES D'INCENDIE OU  
D'ELECTROCUTION, N'EXPOSEZ PAS CET ARTICLE  
A LA PLUIE OU A L'HUMIDITE



The lightning flash with arrowhead symbol within an equilateral triangle is intended to alert the user to the presence of uninsulated "dangerous voltage" within the product's enclosure that may be of sufficient magnitude to constitute a risk of electric shock to persons.

Le symbole éclair avec point de flèche à l'intérieur d'un triangle équilatéral est utilisé pour alerter l'utilisateur de la présence à l'intérieur du coffret de "voltage dangereux" non isolé d'ampleur suffisante pour constituer un risque d'électrocution.



The exclamation point within an equilateral triangle is intended to alert the user of the presence of important operating and maintenance (servicing) instructions in the literature accompanying the appliance.

Le point d'exclamation à l'intérieur d'un triangle équilatéral est employé pour alerter les utilisateurs de la présence d'instructions importantes pour le fonctionnement et l'entretien (service) dans le livret d'instruction accompagnant l'appareil.

## IMPORTANT SAFETY INSTRUCTIONS

1. Read these instructions.
2. Keep these instructions.
3. Heed all warnings.
4. Follow all instructions.
5. Do not use this apparatus near water.
6. Clean only with a dry cloth.
7. Do not block any ventilation openings. Install in accordance with the manufacturer's instructions.
8. Do not install near any heat sources such as radiators, heat registers, stoves, or other apparatus (including amplifiers) that produce heat.
9. Do not defeat the safety purpose of the polarized or grounding-type plug. A polarized plug has two blades with one wider than the other. A grounding-type plug has two blades and a third grounding prong. The wide blade or the third prong are provided for your safety. If the provided plug does not fit into your outlet, consult an electrician for replacement of the obsolete outlet.
10. Protect the power cord from being walked on or pinched particularly at plugs, convenience receptacles, and the point where they exit from the apparatus.
11. Only use attachments/accessories specified by the manufacturer.
12. Use only with a cart, stand, tripod, bracket, or table specified by the manufacturer, or sold with the apparatus. When a cart is used, use caution when moving the cart/apparatus combination to avoid injury from tip-over.

### PORTABLE CART WARNING



Carts and stands - The Component should be used only with a cart or stand that is recommended by the manufacturer.

A Component and cart combination should be moved with care. Quick stops, excessive force, and uneven surfaces may cause the Component and cart combination to overturn.

13. Unplug this apparatus during lightning storms or when unused for long periods of time.
14. Refer all servicing to qualified service personnel. Servicing is required when the apparatus has been damaged in any way, such as when the power-supply cord or plug has been damaged, liquid has been spilled or objects have fallen into the apparatus, the apparatus has been exposed to rain or moisture, does not operate normally, or has been dropped.
15. This apparatus shall not be exposed to dripping or splashing, and no object filled with liquids, such as vases, shall be placed on the apparatus.
16. The AC adapter is used as the power disconnect device and should remain readily accessible to the user.
17. This apparatus does not exceed the Class A/Class B (whichever is applicable) limits for radio noise emissions from digital apparatus as set out in the radio interference regulations of the Canadian Department of Communications.

ATTENTION –Le présent appareil numérique n'émet pas de bruits radioélectriques dépassant les limites applicables aux appareils numériques de class A/de class B (selon le cas) prescrites dans le règlement sur le brouillage radioélectrique édicté par les ministere des communications du Canada.

18. Exposure to extremely high noise levels may cause permanent hearing loss. Individuals vary considerably in susceptibility to noise-induced hearing loss, but nearly everyone will lose some hearing if exposed to sufficiently intense noise for a period of time. The U.S. Government's Occupational Safety and Health Administration (OSHA) has specified the permissible noise level exposures shown in the following chart.

According to OSHA, any exposure in excess of these permissible limits could result in some hearing loss. To ensure against potentially dangerous exposure to high sound pressure levels, it is recommended that all persons exposed to equipment capable of producing high sound pressure levels use hearing protectors while the equipment is in operation. Ear plugs or protectors in the ear canals or over the ears must be worn when operating the equipment in order to prevent permanent hearing loss if exposure is in excess of the limits set forth here.

Duration Per Day In Hours	Sound Level dBA, Slow Response	Typical Example
8	90	Packed garage concert
6	92	
4	95	VW Bus Peace Train
3	97	
2	100	Cranked psychedelic tunes
1.5	102	
1	105	High speed chase on C.H.I.P.s
0.5	110	
0.25 or less	115	Loudest parts at a Heavy Metal concert

**WARNING – To reduce the risk of fire or electric shock, do not expose this appliance to rain or moisture.**

# CONTENTS

IMPORTANT SAFETY INSTRUCTIONS.....	2
GETTING STARTED .....	4
INTRODUCTION.....	6
HOOKUP DIAGRAMS.....	7
MIX SERIES FEATURES .....	8
CHANNEL INPUTS .....	8
CHANNEL CONTROLS.....	8
AUX RETURN SECTION.....	10
TAPE SECTION.....	10
MAIN SECTION.....	12
OUTPUT CONNECTIONS .....	13
REAR PANEL FEATURES .....	14
APPENDIX A: SERVICE INFORMATION .....	15
APPENDIX B: CONNECTIONS .....	16
APPENDIX C: MIX SERIES SPECIFICATIONS ..	17
Block Diagram Mix.50.....	19
Block Diagram Mix.60.....	20
Block Diagram Mix.100.....	21
Block Diagram Mix.120.....	22
TAPCO LIMITED WARRANTY .....	23

**Don't forget to visit our website at [www.tapcoworld.com](http://www.tapcoworld.com)  
for more information about this and other TAPCO products.**

---

## What me, read a manual?

Before you begin, please make sure you read the Safety Instructions on page 2 and Getting Started on page 4.

Your new TAPCO® MIX Series mixer is designed to set up quickly and operate easily. We know it's often seen as a sign of weakness to read a manual, along with asking for directions when lost, but maybe you can read the rest when nobody is looking.

It is important to keep your receipt in a safe place, and not a bad idea to write your product information here for future reference (i.e., insurance claims, tech support, return authorization, etc.).

**Product Serial #:**

**Purchased at:**

**Date of purchase:**



# GETTING STARTED

The following steps will help you set up your mixer, and get the levels and adjustments just right.

## ZERO THE CONTROLS:

1. Leave the POWER cord disconnected from the MIX Series mixer.
2. Turn down the channel strip GAIN, AUX SEND, and LEVEL controls.
3. Center the channel strip EQ and PAN/BAL controls.
4. Turn down the MASTER AUX SEND and CTRL ROOM/PHONES controls.
5. Leave all switches out (up).
6. Turn down the MAIN MIX control.

## CONNECTIONS:

1. Connect your speakers to your amplifier's outputs (unless, of course, you have powered speakers).
2. Using TS or TRS cables, make connections from your mixer's MAIN OUT to your amplification system's line inputs.
3. Connect your microphones and instruments to the mixer: Connect microphones to the mono channel MIC INPUT jacks. (For condenser microphones, engage the PHANTOM POWER switch – not available on the Mix.50.) Connect line-level signal sources to the LINE input jacks.  
**Note:** Normally, you would plug in only one microphone or one instrument into each mono channel.
4. Zero the controls, as described above (if you haven't done so already).
5. Connect the power cord supplied with your mixer to the POWER connection on the back and plug it into an AC outlet properly configured for your model.
6. Plug all other sound system components into suitable AC outlets, properly grounded and capable of delivering adequate current.
7. Turn all the power switches on, leaving the speaker's amplifier's switch for last.  
**Note:** There is no power switch on the MIX Series mixers. They are powered up as soon as they are plugged in to an AC outlet.
8. Turn up the MAIN MIX control to the 9 o'clock position (for the Mix.50 and Mix.60) or to the -10 mark (for the Mix.100 and Mix.120), for now. We'll crank it up later on.
9. Now you are ready to set the levels.

## SET THE LEVELS (Mic/Line Channels):

1. Choose one of the microphones or instruments you connected to the mono MIC or LINE input. Make some noise. If it's a microphone, sing at your normal singing volume. If it's an instrument, play it at its normal output level.
2. While making noise, turn up that channel's GAIN until the PEAK LED (next to the PAN control) starts blinking.
3. Raise that channel's LEVEL to unity gain (**U** label). You should be hearing your noise now.
4. If necessary, apply channel EQ changes. (You may need to compensate for level changes afterward with the channel LEVEL control.)
5. Repeat steps 1 through 4 for the other Mic/Line channel(s).
6. Stop making noise. Everyone: start making music.
7. Now turn up the MAIN MIX control to a comfortable listening level.

## SET THE LEVELS (Stereo Line Channels):

1. Make some noise with the mono or stereo instrument connected to the LINE IN jacks on a stereo line-input channel.
2. Adjust the line-input signal level at the source until the PEAK LED (next to the PAN control) starts blinking.  
**Note:** The Mix.50 does not have PEAK LEDs on its two stereo channels. In that case, set the input signal to its normal operating level, but listen for any signs of distortion. If the signal sounds distorted (and not on purpose!), then turn down the input signal at the source.
3. Raise that channel's LEVEL control until it is approximately equal in volume to the microphones or instruments connected to channels 1 and 2.
4. If necessary, apply channel EQ changes (the Mix.50 does not have EQ controls on the stereo channels). (You may need to compensate for level changes afterward with the channel LEVEL control.)
5. Repeat steps 1 through 4 for the remaining stereo channels.

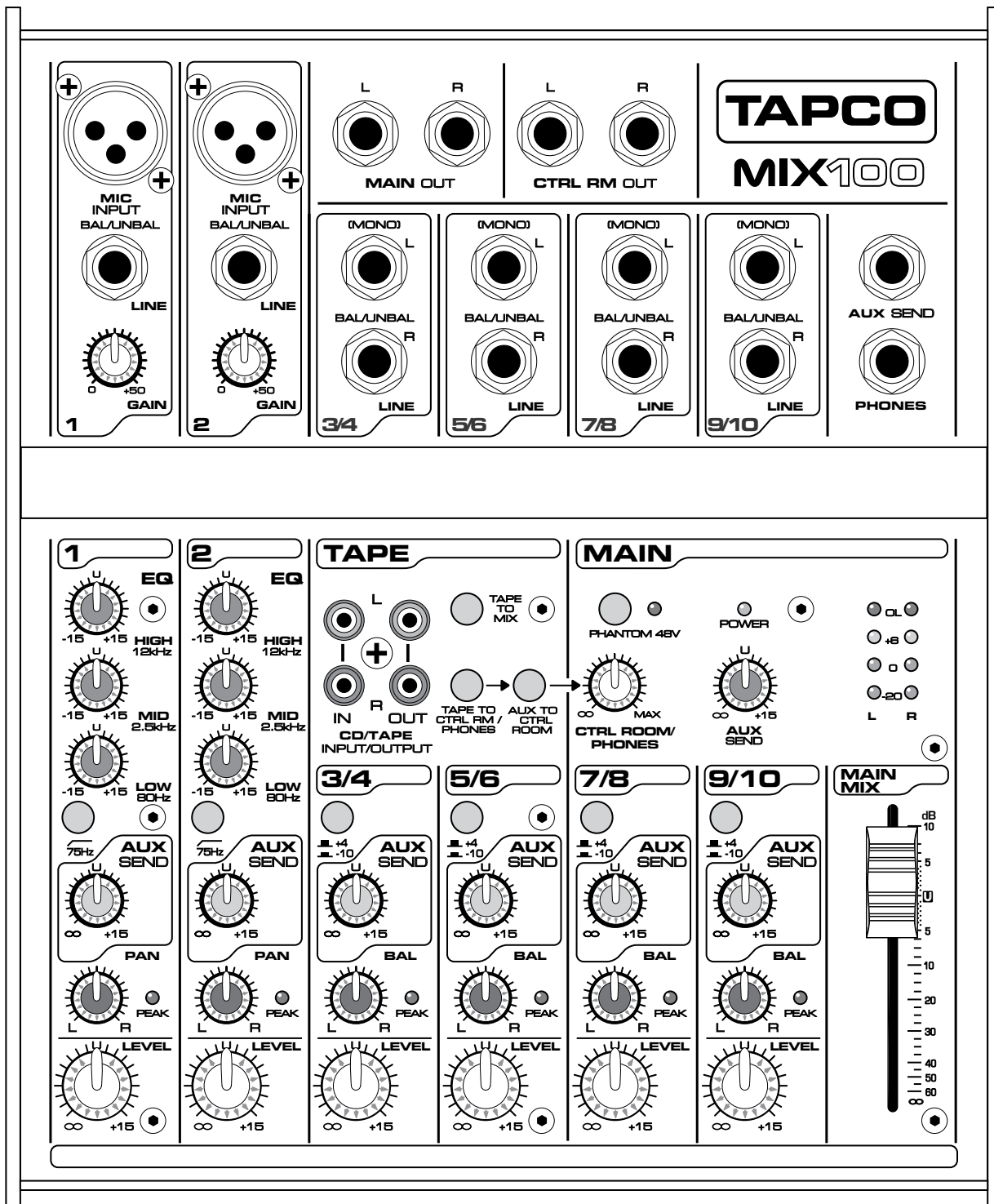

**A FEW PRECAUTIONS:**

- Never listen to loud music for prolonged periods. Please see the Safety Instructions on page 2 for information on hearing protection.
- Never plug amplifier speaker-level outputs into anything except speakers.
- Never use guitar cables to connect amplifiers to speakers.
- Before making connections to an external amplifier, or reconfiguring an amp's routing, turn the amp's level (gain) controls down, turn the power off, make the changes, turn the power back on, and then turn the level controls back up.
- When you shut down your equipment, turn off any external amplifiers first. When powering up, turn on the amplifiers last.
- Save the shipping box and packing material! The box can also be turned into a unique hat, lunch box, or handbag to accessorize your mixer.

# INTRODUCTION

Thank you for choosing a TAPCO MIX Series mixer. The TAPCO family of mixers hails back to the days of TAPCO Corporation, Greg Mackie's first company. TAPCO revolutionized the audio industry back in 1969 with the very first 6-channel mixer specifically designed for keyboards and rock 'N' roll PA.

The first TAPCO mixer, although primitive by today's standards, was truly innovative for its time. It had the headroom to handle screaming singers, was priced for the pocketbook of starving psychedelic musical neophytes, and durable enough to withstand mammoth levels of wear and tear on the road, and at now-legendary concerts.

In essence, TAPCO re-defined the price performance ratio and made high-quality professional audio mixers accessible to virtually anyone. Today, TAPCO is reborn with the same ideals and is backed by the world-class engineering and manufacturing horsepower of LOUD Technologies.

These compact mixers are perfect for small to medium-sized live sound reinforcement applications, keyboards and synths, video, and small-project studio applications.

## HERE'S A QUICK GLANCE AT ALL THE FEATURES PACKED INTO THESE MIXERS:

### **Mono mic/line channels:**

- Variable input trim (0 to +50 dB)
- Phantom power, globally switched (except Mix.50)
- Level Set/PEAK indicator LED
- XLR microphone input jack
- 1/4" TRS line-input jack
- Post-fader aux send (except Mix.50)
- 3-band EQ (2-band EQ on Mix.50)
- 75 Hz low-cut filter (Mix.100/Mix.120 only)
- Pan control
- Rotary level control

### **Stereo line channels:**

- Left and right 1/4" TRS line input jacks
- +4/-10 input level switch (Mix.100/Mix.120 only)
- Level Set/PEAK indicator LED (except Mix.50)
- Post-fader aux send (except Mix.50)
- 3-band EQ (Mix.60 only)
- Balance control
- Rotary level control

### **Master section:**

- Rotary stereo Main Mix control (Mix.50/Mix.60)
- 60mm fader Main Mix control (Mix.100/Mix.120)
- Balanced 1/4" TRS stereo main outputs
- 4-segment stereo LED VU metering
- 1/4" TRS Aux Send with rotary level control (except Mix.50)

- Stereo RCA tape out and tape in
- Master +48V phantom power switch with LED indicator (except Mix.50)
- Left and Right 1/4" TRS Control Room outputs and stereo 1/4" Phones output with rotary level control (Phones only on Mix.50)
- Tape to Control Room/Phones switch (Tape to Phones on Mix.50)
- Aux to Control Room switch (Mix.100/Mix.120 only)
- Tape to Mix switch
- Power LED indicator
- Inter-Planetary Space Drive control
- OK, we made that last one up, but we can pencil it in for next time

# HOOKUP DIAGRAMS

Mono in/Stereo out Reverb (optional)

## Small Club Gig

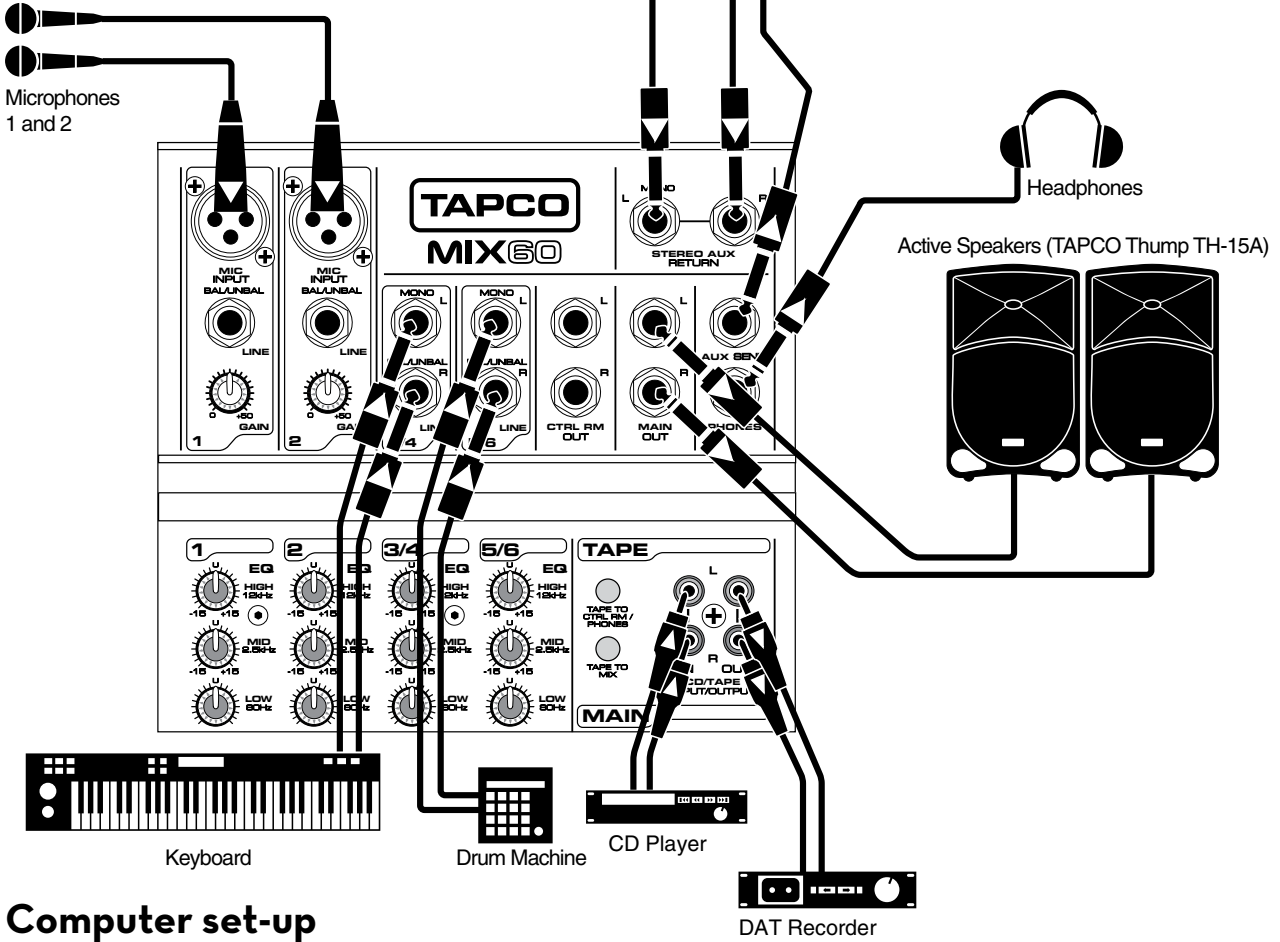

## Computer set-up

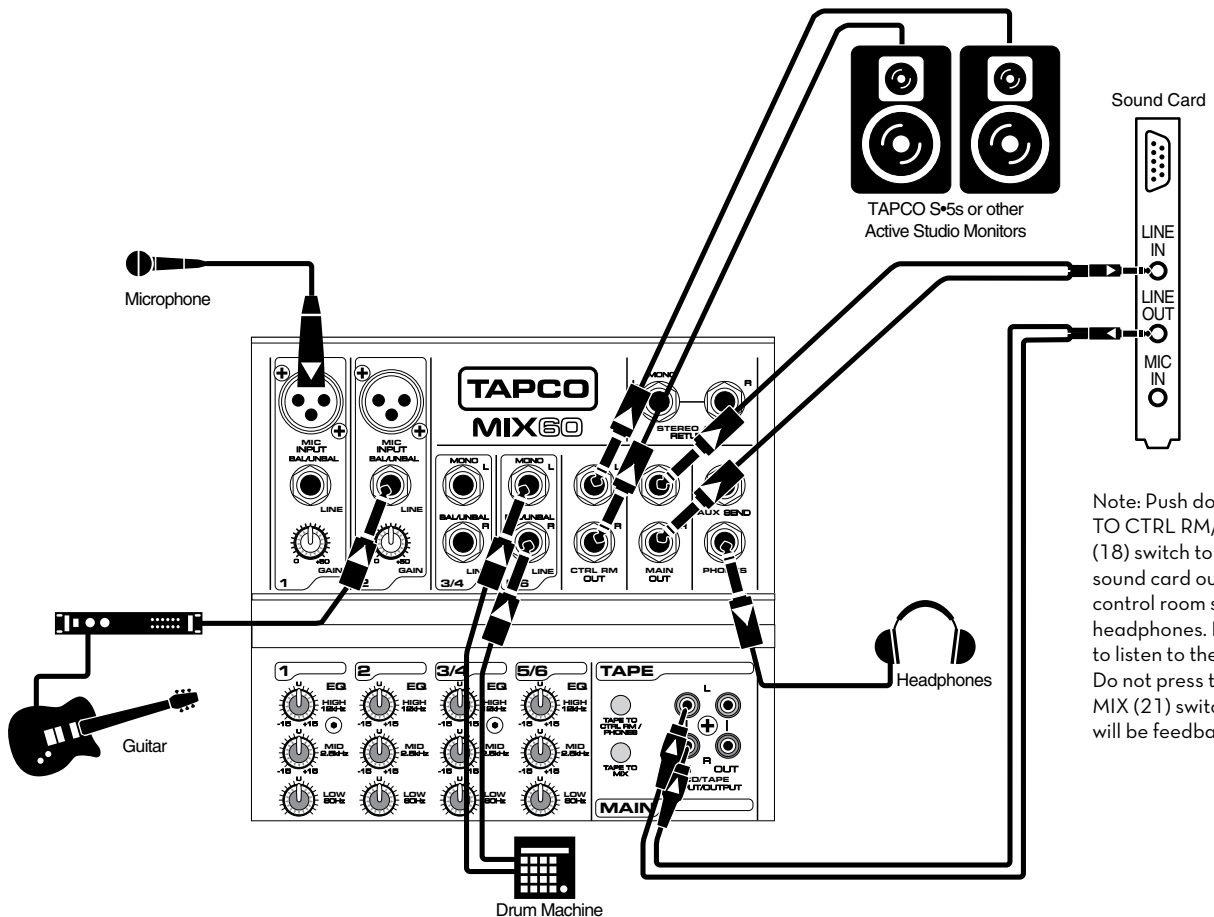

Note: Push down the TAPE TO CTRL RM/PHONES (18) switch to listen to the sound card output in the control room speakers and headphones. Leave it up to listen to the main mix. Do not press the TAPE TO MIX (21) switch, or there will be feedback.

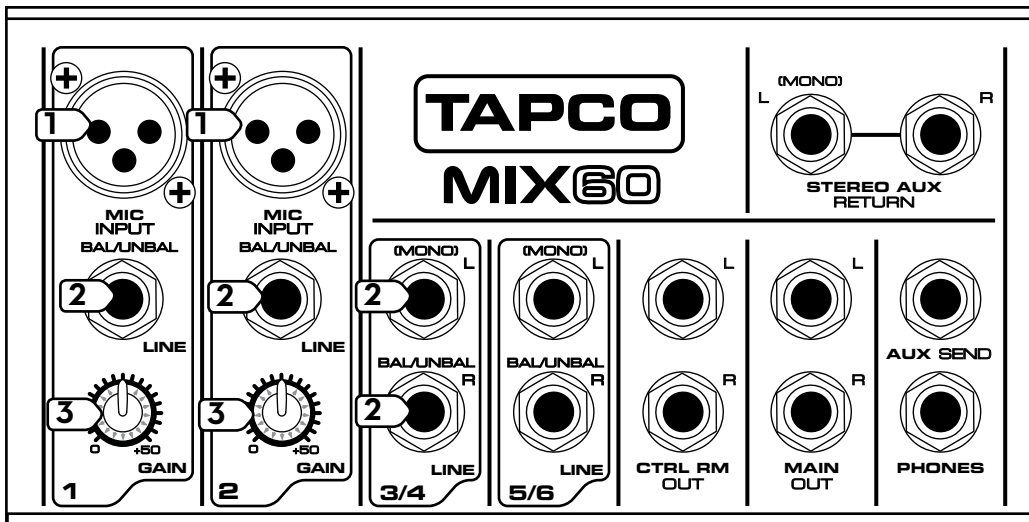

# MIX SERIES FEATURES

## CHANNEL INPUTS

### 1. MIC (MICROPHONE) INPUTS

The MIX Series is equipped with one or more rugged, low-noise, phantom-powered microphone preamplifiers, providing up to 50 dB of crystal-clear amplification (no phantom power on Mix.50). Their balanced circuitry rejects all manner of extraneous interference. Professional condenser, dynamic, and ribbon mics all sound excellent through these XLR inputs.

You can plug in almost any kind of balanced mic that has a standard XLR-type male mic connector. See Appendix B for more information on XLR connectors.

The MIX Series provides +48 VDC phantom powering on pins 2 and 3 of the mono channels' XLR MIC inputs (except Mix.50). This can be turned on and off using the PHANTOM (19) switch.



**CAUTION:** DO NOT connect a line-level device to a MIC input with the phantom power switched on. This could damage the device. Use the LINE IN (2) jacks instead.

Do not use phantom power with tube or ribbon microphones, as this may cause damage.

### 2. LINE INPUTS

These inputs can accept 1/4" TRS balanced and TS unbalanced plugs from any line-level instrument, effects device, or tape player. They can be driven by virtually any line-level signal, from -45 dBu up to +18 dBu.

There are two line-inputs for each stereo channel, a left and a right. When connecting a stereo device (two cords), use both the left (mono) input and the right input.

When connecting a mono device (just one cord), always use the left (mono) input and plug nothing into the right input. A trick called "jack normalling" causes the signal to appear on both sides.

### 3. GAIN CONTROL

If you haven't already, please read "SET THE LEVELS" on page 4.

The GAIN control adjusts the input sensitivity of the MIC and LINE inputs. This allows signals from the outside world to be adjusted to optimal internal operating levels.

The GAIN control provides 50 dB of gain with the knob fully up.

### 4. PEAK LED

This handy LED (Light Emitting Diode) lets you know that the signals going into the mixer are adjusted to the correct level, not too strong to cause distortion and not too weak to be lost in noise.

After you connect a microphone or line-level component to the mixer, do a sound test and adjust the GAIN control until this handy LED flickers just occasionally. If it is glowing constantly, turn the GAIN down. If the LED is doing almost nothing, turn it up.

## CHANNEL CONTROLS

The channel strips have various controls, depending on the model and whether it is a mic/line (mono) channel or a stereo channel.

The output from each channel strip passes on to the left and right main mix. An auxiliary signal can be tapped off and sent to monitors or processors (except Mix.50). The block diagrams on pages 19-22 show how the signal flows through each mixer.





## UNITY GAIN

The **U** symbol on most of the controls, stands for “unity gain,” meaning there is no change in signal level. Once you have adjusted the input signal to line-level, you can set every control at **U**, and your signals will travel through the mixer at optimal levels.

## EQUALIZATION

Each EQ control provides up to 15 dB of boost and cut, with no change to the signal (0 dB) in the center position. The mic/line channels have EQ controls on all models. Only the Mix.60 has EQ controls on the stereo channels.

Although you can bring a sound to life with proper EQ, you can also mess things up. If you max the EQs on every channel, you’ll get mix mush, not to mention driving your mix levels near or beyond clipping. So equalize subtly; use cut as well as boost.

### 5. HI EQ

Turning this clockwise boosts the level of all frequencies above 12 kHz. Turning it counter-clockwise cuts the levels.

Use this wisely to add sizzle to cymbals or an overall sense of transparency or edge to keyboards, vocals, guitar, and bacon frying. Turn it down a little to reduce sibilance or hide tape hiss.

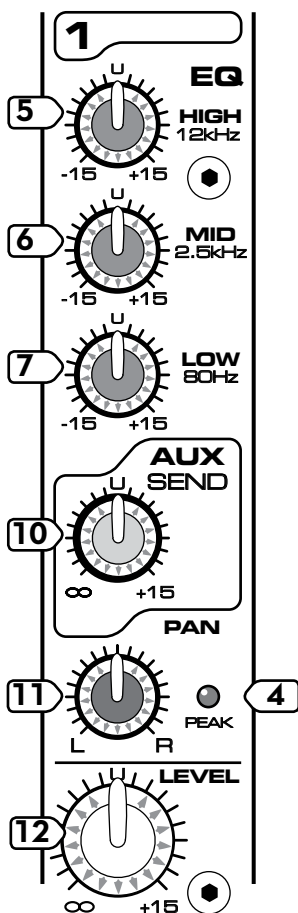

Mix.60 Mono Channel

### 6. MID EQ (all except Mix.50)

Turning this clockwise boosts the level of frequencies at and around 2.5 kHz. Turning it counter-clockwise cuts the levels.

The midrange frequencies include the upper male and lower female vocal ranges, and the fundamentals and harmonics for many instruments.

### 7. LOW EQ

Turning this clockwise boosts the level of all frequencies below 80 Hz. Turning it counter-clockwise cuts the levels.

Frequencies of 80 Hz and below represent the punch in bass drums, bass guitar, fat synth patches, and high-testosterone male singers.

### 8. 75Hz Low-Cut Switch (Mix.100/Mix.120 only)

This switch cuts the bass frequencies below 75 Hz. We recommend that you use the Low-Cut switch on every microphone application except kick drum, bass guitar, bassy synth patches, or recordings of earthquakes. These aside, there isn’t much down there that you want to hear, and filtering it out makes the low stuff you do want much more crisp and tasty.

### 9. +4/-10 Switch (Mix.100/Mix.120 only)

This switch changes the input sensitivity of the channel to match either the -10 dBV consumer level or the +4 dBu professional level. Most consumer equipment with RCA connectors operate at the -10 dBV level, while most professional equipment with 1/4-inch phone jacks or XLR connectors operate at the +4 dBu level.

As you might expect, the +4 dBu level is higher (louder) than the -10 dBV level. If you have trouble getting enough volume from a signal connected to one of these stereo channels, push in the +4/-10 switch to get more volume.

## AUXILIARY (all except Mix.50)

In addition to the main mix output, the mixer provides an auxiliary mix, which you can send to parallel effects processors or stage monitors.

The AUX SEND knobs adjust how much of each channel is tapped off, added to the aux mix, and sent out via the AUX SEND (26) jack.

On the stereo channels, the AUX knob controls a mono sum of the channel’s stereo signals. For instance, on the Mix.60, channel 3 (L) and 4 (R) mix together to feed that channel’s AUX send knob.

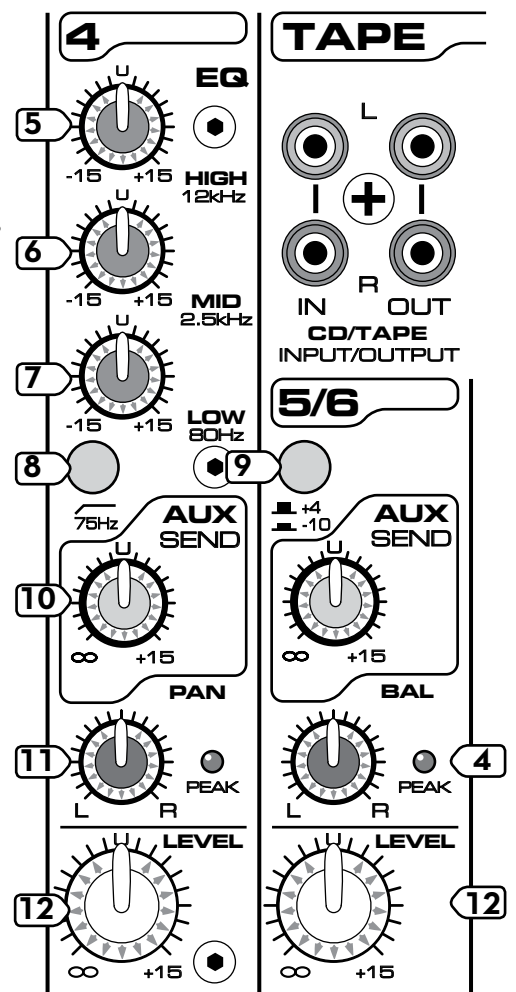

Mix.120 Mono and Stereo Channels

## 10. AUX SEND (all except Mix.50)

The AUX SEND is used to feed the mono input of parallel effects devices or the input of a stage monitor amplifier via the AUX SEND (27) output jack. All the channel controls (except PAN or BAL) will affect the AUX signal. The signal is tapped off **after** the LEVEL control. The output from an external processor can come back in via the STEREO AUX RETURN (13) inputs (on the Mix.60) or a stereo channel (Mix.100/Mix.120), and be added to the main mix.

## 11. PAN/BAL

This adjusts how much of the channel signal plays in the left side of the main mix, and how much plays in the right.

For mono mic/line channels, if PAN is in the center position, the mono signal appears equally in both the left and right of the main mix. If the control is set left, more of the signal appears in the left side. If the control is set right, more of the signal appears in the right side of the mix.

For stereo channels, the BAL control works like a home stereo balance control, by attenuating one side or the other. In the center position, the left and right channel signals pass through to the main mix unaffected. If it is turned left, the right channel is attenuated; if turned right, the left side is attenuated.

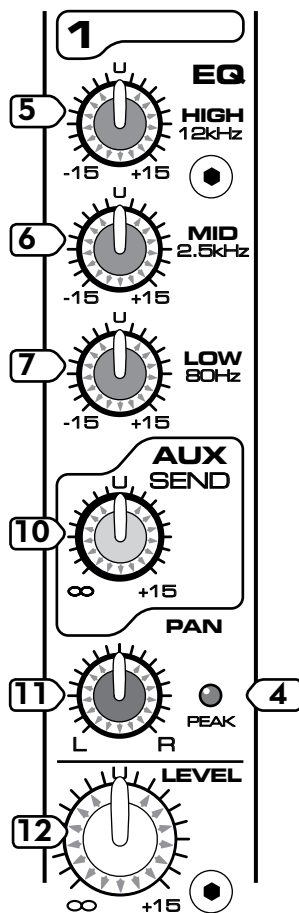

Mix.60 Mono Channel

## 12. LEVEL

This is the master level control for the channel's signal. Subtle adjustment of the channels' level control is the key to a finely-tuned mix.

Typically (providing the GAIN is set correctly), this will be positioned somewhere between 0 dB (U) and the 3 o'clock position.

If you have the LEVEL set all the way up, it's usually a sign that your GAIN is set too low. If LEVEL is set way down, your GAIN may be too high.

**Note:** If this were a slide control instead of a rotary one, it would be called a fader. It still serves as the reference point when talking about pre-fader and post-fader.

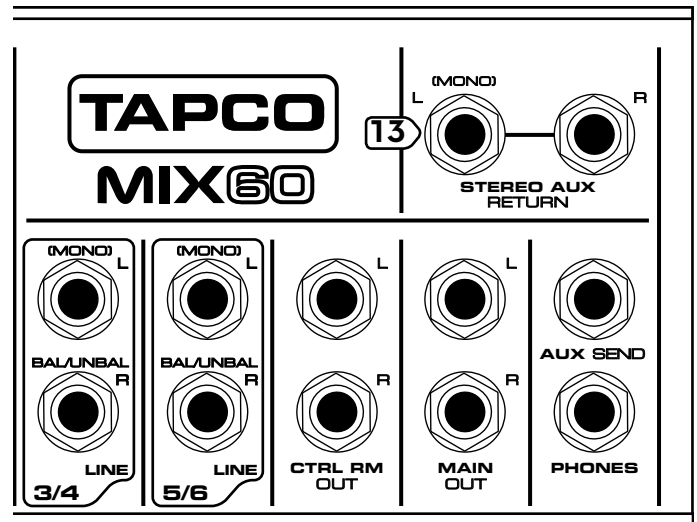

## AUX RETURN SECTION

### 13. STEREO AUX RETURN INPUTS (Mix.60 only)

Connect the outputs of an external parallel effects device into these inputs.

When connecting a mono device (just one cord), always use the left (mono) input and plug nothing into the right input. The signal will appear on both sides.

The signal is added directly into the main mix. There is no level control for the aux return signal, but most external processors have an output level control that you can use to adjust the signal being returned to the mixer.

For the Mix.50, Mix.100, and Mix.120, connect the aux return signal to the inputs of an unused stereo channel. This has the added benefit of providing a level control for the aux return signal.



**CAUTION:** When using a stereo channel as an aux return, **TURN THE AUX SEND CONTROL ALL THE WAY DOWN** on that channel. If you have the Aux Send control turned up even a little, it can create a feedback loop. This would be very bad for your speakers and for your ears.

## TAPE SECTION

### 14. CD/TAPE INPUTS

This is where you connect the outputs of your intermission entertainment. Any line-level mono or stereo device can be used, such as: tape, DVD/CD player, television audio, etc.

Signals coming into these inputs are routed directly to the main mix when the TAPE TO MIX (15) switch is pushed in. The signals can also be routed to

the CONTROL ROOM/PHONES (25/28) outputs when the TAPE TO CTRL RM/PHONES (16) switch is pushed in (TAPE TO PHONES only on the Mix.50).

See Appendix B for more information about RCA connectors.

When connecting a mono device (just one cord), you'll need a "Y-splitter" RCA adapter. It turns a mono output cord into two cords, so both the right and left tape input jacks can be used. This adapter is widely available.

**Note:** There is a chance of feedback if you have the tape inputs and outputs connected to the same recorder, and the recorder is in record mode.

### 15. TAPE TO MIX Switch

If you have a CD or Tape Deck connected to the CD/TAPE inputs, push down this switch to add the CD/TAPE signal to the main mix. This is useful if you want to play some entertainment\* while the band is taking a break. Use the MAIN MIX control to adjust the volume level.

\* We do not mean to imply that your band isn't entertaining, or that any other music could possibly fill in for them.

### 16. TAPE TO CTRL RM/PHONES Switch (TAPE TO PHONES on Mix.50)

Use this switch to select the signal source for the CONTROL ROOM outputs, PHONES, and METERS. When the switch is up, they all receive the main mix signal tapped after the MAIN MIX control.

When the switch is pushed in, they all receive the CD/TAPE Input signal. Turn down the CTRL ROOM/PHONES (21) control (just PHONES on the Mix.50) before engaging.

### 17. AUX TO CTRL ROOM Switch (Mix.100/Mix.120 only)

Push this switch to monitor the aux send signal in the Control Room and Phones outputs. This overrides the TAPE TO CTRL RM/PHONES switch and replaces whatever signal is present at the Control Room and Phones outputs with the aux send signal.

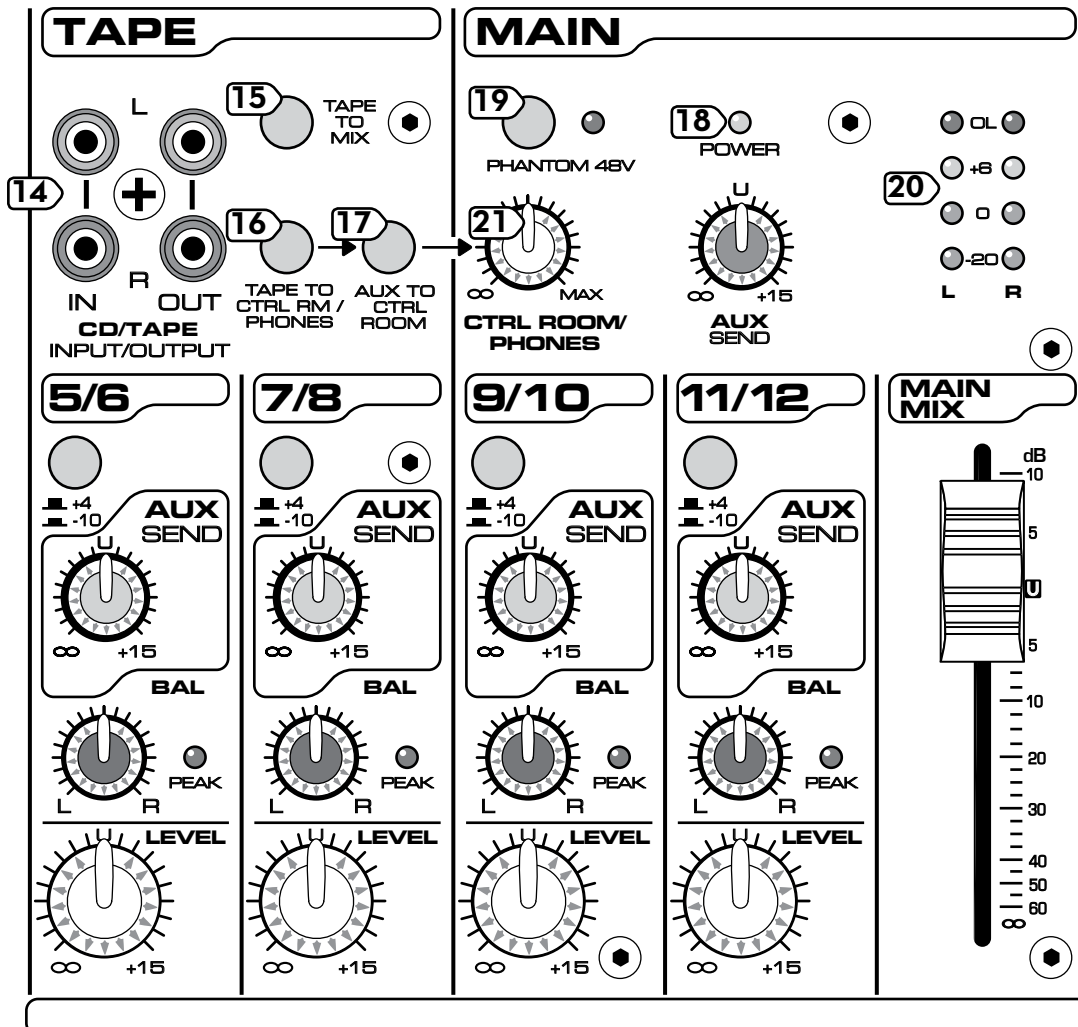

Mix.120 Main Section

# MAIN SECTION

## 18. POWER LED

This LED turns on when the mixer's power cord is plugged into an AC outlet. Since there is no power switch on the MIX Series mixers, the mixer is always on when it is connected to AC power.

## 19. PHANTOM 48V Switch and LED

Push in this switch to provide phantom power to the MIC (1) input XLR jacks. Phantom power is required to operate most condenser microphones (some condenser microphones are battery-powered). With the switch pushed in, the mixer provides +48 VDC phantom powering on XLR pins 2 and 3.

If you have ribbon mics, tube mics, or dynamic mics that do not require phantom power, leave the PHANTOM POWER switch out. If you are using both condenser and dynamic mics, don't worry. Phantom power will not hurt most dynamic mics. Check the microphone's user manual if you're not sure.



**Caution:** Turn all output levels down before operating this switch to avoid the possibility of a "pop" in your speakers. Do not use phantom power with tube or ribbon microphones, as this may cause damage.

## 20. METERS

These left and right meters have four LEDs each, with thresholds ranging from -20 dBu up to +18 dBu (OL = overload).

The 0 dB LED corresponds to an output level of 0 dBu (0.775 V RMS). The OL LEDs turn on when the output reaches +18 dBu. There is a fair margin of safety before actual clipping distortion occurs, but you should turn things down if the OL LEDs come on.

Normally, the meters display the level of the main mix, after the MAIN MIX (23) control.

If the TAPE TO CTRL RM/PHONES (16) switch is pushed in, the meters display the level of the CD/TAPE signal, and not the main mix.

You can get a good mix with the meter's peaks flashing anywhere between -20 and +6 dB. Most amplifiers clip at about +10 dB, and some recorders aren't so forgiving either. For best real-world results, try to keep your peaks between "0" and "+6."

If your meters are too high, you will get distortion. If they are too low, then your signal-to-noise will suffer. Use the meters to help you adjust the mixer for optimum performance without distortion or noise. Then you can adjust your amplifier's level controls for good overall volume. This will give you the best overall signal-to-noise ratio for your system.

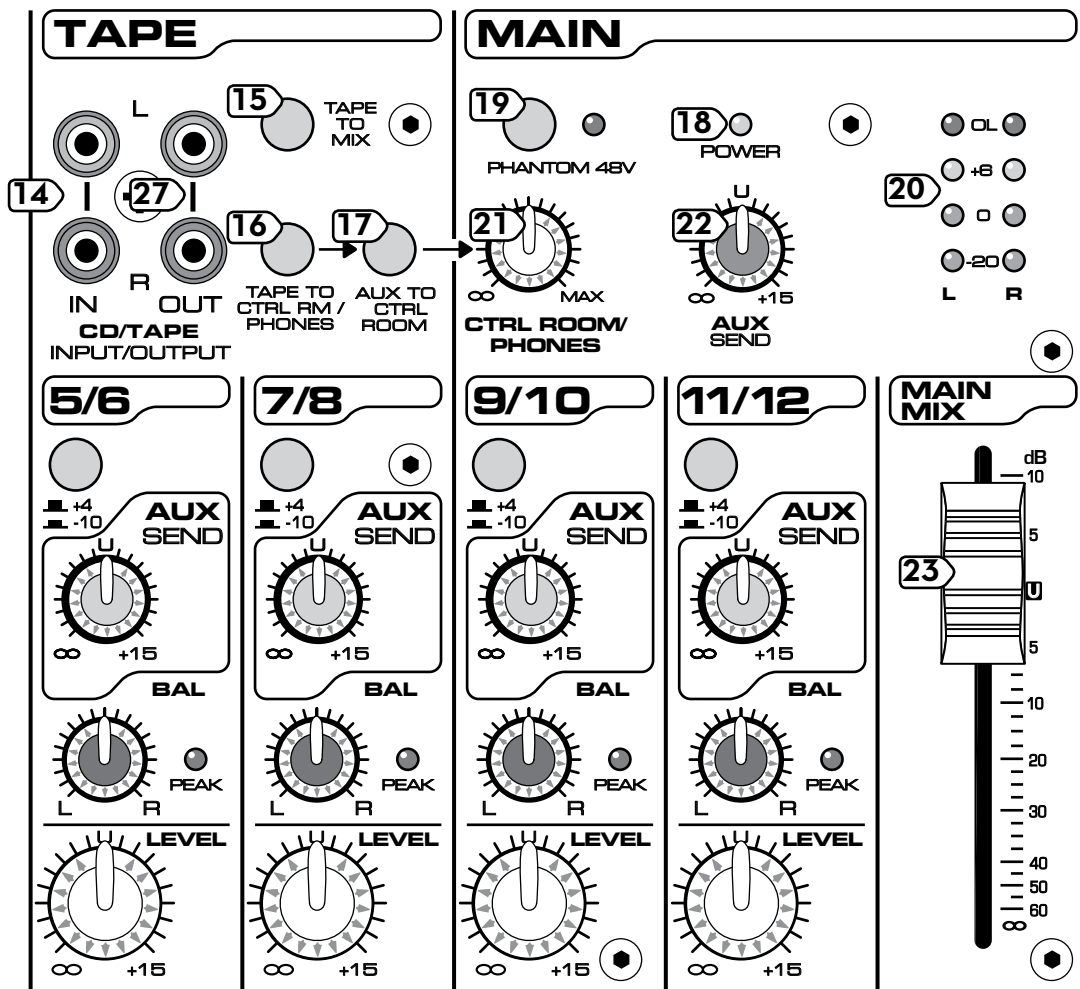

## 21. CTRL ROOM/PHONES Knob (PHONES Knob on the Mix.50)

This adjusts the signal level going to the CONTROL ROOM (25) and PHONES (28) outputs. It has no effect on the Main Mix output.



**WARNING:** The headphone amp is designed to drive any standard headphones to a very loud level. We're not kidding! It can cause permanent hearing damage. Even intermediate levels may be painfully

loud with some headphones. **BE CAREFUL!** Always start with the CTRL ROOM/PHONE knob turned all the way down before connecting headphones to the PHONES jack. Keep it down until you've put on the headphones. Then turn it up slowly. Why? Always remember: **"Engineers who fry their ears, find themselves with short careers."**

## 22. MASTER AUX SEND Knob (all except Mix.50)

The Master AUX SEND knob provides overall control for the aux send level, just before it is delivered to the Aux Send output.

It ranges from off when fully counter-clockwise, to unity gain at the center detent position, to +15 dB gain when fully up.

## 23. MAIN MIX

This controls the final level of main mix signals sent to the MAIN (24) outputs, TAPE (27) outputs, CONTROL ROOM (25), PHONES (28) and METERS (20). So it all comes down to this one control.

On the Mix.50 and Mix.60, this is a rotary control. Typically (providing the GAIN is set correctly), this will be positioned somewhere between 0 dB (**U**) and the 3 o'clock position.

On the Mix.100 and Mix.120, this is a slide control (fader). Typically, the fader will be positioned somewhere between 0 dB (**U**) and the +5 dB position.

All active mono and stereo channels that are not turned down will appear in the main mix. Other signals feeding this control include the STEREO AUX RETURN (13) (Mix.60), and CD/TAPE IN (14) when TAPE TO MIX (15) is pushed in.

## OUTPUT CONNECTIONS

### 24. MAIN OUT

These 1/4" TRS jacks represent the end of the mixer chain, where your fully mixed stereo signal enters the real world.

Connect these outputs to the inputs of your amplifiers, powered speakers, or serial effects processor (graphic equalizer, for example).

### 25. CTRL ROOM OUT

These 1/4" TRS jacks can be used to provide another main mix output, or to monitor the CD/Tape Inputs (TAPE TO CTRL RM/PHONES switch pushed in), or to monitor the aux send signal (Mix.100/Mix.120 only with AUX TO CTRL ROOM switch pushed in).

Connect these outputs to the inputs of an amplifier, powered speakers, or recording device.

### 26. AUX SEND OUT

Connect this 1/4" TRS output to the input of an external effects processor.

Each channel strip has an AUX SEND control knob that adjusts how much of that channel's signal appears at this output. The output from this jack is the sum of all those active channels that have their AUX SEND knobs set to more than the minimum position.

This output **is** affected by the channel LEVEL (12), but not the MAIN MIX (23) control.

**Note:** Since this output is post-channel EQ and LEVEL, it is not used as a traditional stage monitor cue. It is intended to patch into an effects device's input.

That said, we're not going to stop you from using it as a monitor feed if you want to. To create a stage monitor mix, connect this 1/4" TRS output to your monitor amplifier's input, or powered monitor's input.

### 27. TAPE OUTPUTS

Use these jacks to capture the entire performance to tape. The signal at these jacks is a sample of the main mix, as it appears at the MAIN (24) output. The TAPE OUTPUT level is affected by the MAIN MIX (23) control.

### 28. PHONES OUTPUT

The stereo signal at this output jack is the same as the CTRL ROOM (25) outputs, and is controlled by the same CTRL ROOM/PHONES level control knob (21). You can listen to the main mix, the CD/TAPE, or the Aux Send (Mix.100/Mix.120 only) depending

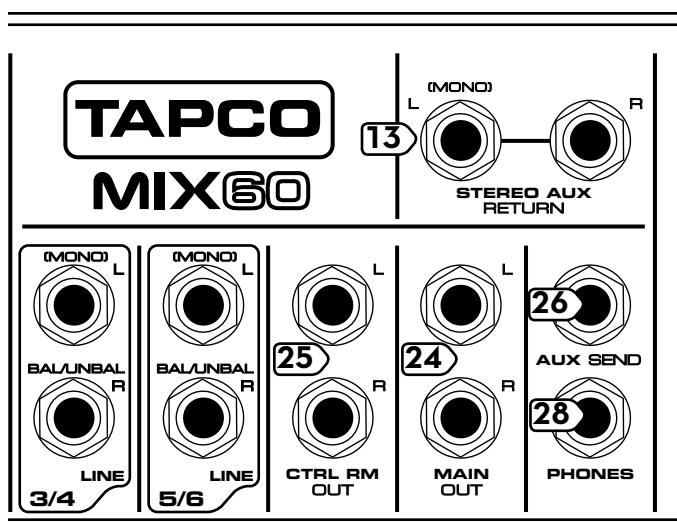

upon the position of the TAPE TO CTRL RM/  
PHONES (16) switch and the AUX TO CTRL ROOM  
(17) switch.



**Note:** Be very careful because the PHONES jack can drive any standard headphones to very loud levels. Please see page 2 for information on hearing protection.

See Appendix B for information about 1/4" TRS stereo connectors.

## REAR PANEL FEATURES

### 29. POWER IN

This connection is where you connect the supplied external AC power supply to provide AC power to the mixer. Connect the external power supply to the MIX Series mixer first, then plug the power supply into a suitable and properly rated AC outlet.

**WARNING:** Make sure you use the correct external power supply capable of providing 18.5 VACx2 at 150 milliamps.

### 30. Kensington Security Slot

To help prevent theft, all the MIX Series mixers have a security slot designed to fit the popular Kensington security locks. A variety of models are available from their website at [www.kensington.com](http://www.kensington.com).

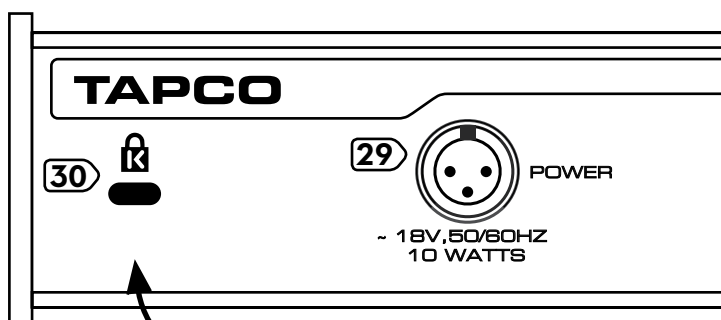

# APPENDIX A: SERVICE INFORMATION

If you think your TAPCO product has a problem, please check out the following troubleshooting tips and do your best to confirm the problem. Visit the “Talk To Each Other” section of our website ([www.tapcoworld.com](http://www.tapcoworld.com)) where you will find user forums to exchange information and ideas. You may find the answer to the problem without having to send your TAPCO product away.

## Troubleshooting

### Bad Channel

- Is the channel GAIN turned up?
- Is the channel LEVEL turned up?
- Try the same source signal in another channel, set up exactly like the suspect channel.

### Bad Output

- IS the MAIN MIX control turned up?
- If it's a stereo pair, try switching them around. For example, if a left output is presumed dead, switch the left and right cords, at the mixer end. If the left speaker is still dead, it's not the mixer.

### Noise

- Turn the channel LEVEL controls down, one by one. If the noise disappears, it's either that channel or whatever is plugged into it, so unplug whatever that is.

### Power

- Our favorite question: Is the POWER switch on? Ha! Fooled you. There is no POWER switch.
- Is the external power supply securely plugged into the POWER connector on the back of the Mix Series mixer?
- Is the external power supply plugged into an AC power strip? Make sure the power to the power strip is turned on.
- Are all the lights out in your building?

### Repair

For warranty repair or replacement, refer to the warranty information on page 23.

Non-warranty repair for TAPCO products is available at a factory-authorized service center. To locate your nearest service center, call our Tech Support department at 1-800-827-2669, Monday-Friday, 7 am to 5 pm Pacific Time, to explain the problem. Tech Support will tell you where the nearest factory-authorized service center is located in your area.

**Lonely? Looking for that special someone?**

**Do you have a question about your TAPCO Mixer?**

Please call our Technical Support chaps at **1-877-827-2669**, Monday to Friday, from 7 am to 5 pm PST. After hours, visit [www.tapcoworld.com](http://www.tapcoworld.com) and look under **Talk To Us**, or e-mail us at [techmail@tapcogear.com](mailto:techmail@tapcogear.com)

# APPENDIX B: CONNECTIONS

## XLR Connectors

The Mic/Line Channels use 3-pin female XLR connectors on the MIC inputs. They are wired as follows, according to standards specified by the AES (Audio Engineering Society).

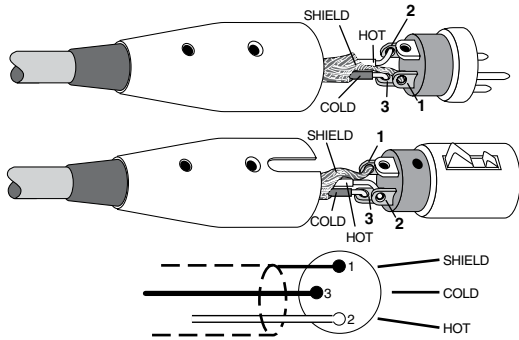

### XLR Balanced Wiring:

- Pin 1 = Shield
- Pin 2 = Hot (+)
- Pin 3 = Cold (-)

## 1/4" TRS Phone Plugs and Jacks

"TRS" stands for Tip-Ring-Sleeve, the three connections available on a stereo 1/4" or balanced phone jack or plug. TRS jacks and plugs are used for balanced signals and stereo headphones:

### Balanced Mono

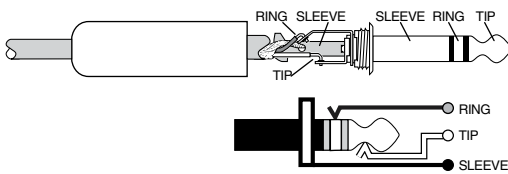

### 1/4" TRS Balanced Mono wiring:

- Sleeve = Shield
- Tip = Hot (+)
- Ring = Cold (-)

### Stereo Headphones

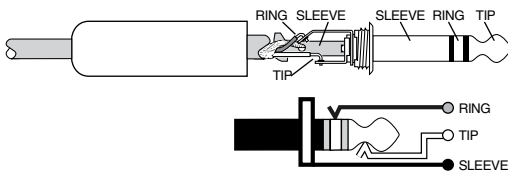

### 1/4" TRS Stereo Unbalanced Wiring:

- Sleeve = Shield
- Tip = Left
- Ring = Right

## 1/4" TS Phone Plugs and Jacks

"TS" stands for Tip-Sleeve, the two connections available on a mono 1/4" phone jack or plug. They are used for unbalanced signals.

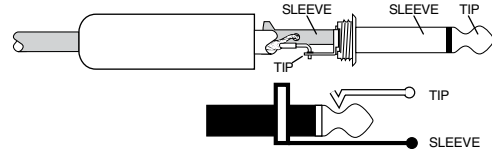

### 1/4" TS Unbalanced Wiring:

- Sleeve = Shield
- Tip = Hot (+)

## RCA Plugs and Jacks

RCA-type plugs (also known as phono plugs) and jacks are often used in home stereo and video equipment and in many other applications. They are unbalanced and electrically equivalent to a 1/4" TS phone plug.

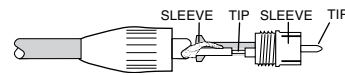

### RCA Unbalanced Wiring:

- Sleeve = Shield
- Tip = Hot



# APPENDIX C: MIX SERIES SPECIFICATIONS

## Frequency Response

Mic Input to any Output (Trim at 0 dB):  
+0, -1 dB,  
10 Hz to 150 kHz  
-3 dB,  
10 Hz to 200 kHz

## Distortion

THD and SMPTE IMD; 20Hz to 20kHz  
Mic Input to Main Output:  
< 0.005%  
@ +4 dBu output

## Noise

20 Hz to 20 kHz BW (150Ω source impedance)  
Equivalent Input Noise (EIN): -129 dBu  
Residual Output Noise:  
Channel and Main Mix levels off  
Main, Ctrl Room, Phones: -106 dBu

## Common Mode Rejection Ratio (CMRR)

Mic In: 60 dB @ 1 kHz  
Gain @ maximum

## Crosstalk

Adjacent Inputs or Input to Output:  
-90 dB @ 1 kHz

## Input Gain Control Range

0 dB to +50 dB

## Phantom Power

+48 VDC

## Equalization

Mono Channel EQ (Mix.50 only):  
High ±15 dB @ 12 kHz  
Low ±15 dB @ 80 Hz  
Mono Channel EQ (Mix.60, Mix.100, Mix.120)  
Stereo Channel EQ (Mix.60):  
High ±15 dB @ 12 kHz  
Mid ±15 dB @ 2.5 kHz  
Low ±15 dB @ 80 Hz

## Mixer Rated Output

Main, Aux, Control Room: +4 dBu  
Maximum Rated Output: +22 dBu

## Maximum Input Levels

Mic Input: +12 dBu,  
Gain @ +10 dB  
Line Input: +30 dBu,  
Gain @ +10 dB  
Tape Input and Aux Return: +22 dBu

## Input Impedance

Mic Input: 2.6 kΩ, balanced  
Line Input: 20 kΩ, balanced  
Stereo Aux Returns: 20 kΩ, balanced  
CD/Tape In: 24 kΩ, unbalanced

## Output Impedance

Main 240 Ω, balanced  
120 Ω, unbalanced  
Ctrl Room, Aux Sends: 120 Ω  
Tape Output: 1 kΩ  
Phones Output: 25 Ω

## VU Meters

Main Left and Right  
4 segments:  
Clip (+18), +6, 0, -20  
0 LED = 0 dBu

## AC Power Requirements

External Power Supply output:  
Mix.50 18.5 VAC x 2 @ 150 mA  
Mix.60 18.5 VAC x 2 @ 350 mA  
Mix.100 18.5 VAC x 2 @ 350 mA  
Mix.120 18.5 VAC x 2 @ 350 mA  
(3-pin AC power connection)

External Power Supply AC input  
U.S. 120 VAC, 60 Hz  
Europe 230/240 VAC, 50 Hz  
Japan 100 VAC, 50/60 Hz  
Korea 220 VAC, 60 Hz

## Physical Dimensions and Weight

### Mix.50

Height: 1.6 in/41 mm  
 Width: 5.2 in/133 mm  
 Depth: 8.0 in/203 mm  
 Weight: 2.0 lb/0.9 kg

### Mix.60

Height: 1.6 in/41 mm  
 Width: 7.4 in/188 mm  
 Depth: 9.9 in/252 mm  
 Weight: 3.0 lb/1.4 kg

### Mix.100

Height: 1.6 in/41 mm  
 Width: 8.5 in/215 mm  
 Depth: 10.2 in/259 mm  
 Weight: 3.4 lb/1.5 kg

### Mix.120

Height: 1.6 in/41 mm  
 Width: 10.7 in/272 mm  
 Depth: 10.2 in/259 mm  
 Weight: 4.1 lb/1.9 kg

## Disclaimer

Since we are always striving to make our products better by incorporating new and improved materials, components, and manufacturing methods, we reserve the right to change these specifications at any time without notice.

The TAPCO Mix mixers were recently accidentally awarded first prize by the Society of Juicers, Mixers and Blenders in the "Quadruple Planetary Mixers" category.

"TAPCO" is a registered trademark of LOUD Technologies Inc. All other brand names mentioned are trademarks or registered trademarks of their respective holders, and are hereby acknowledged.

©2005-2008 LOUD Technologies Inc.  
 All Rights Reserved.

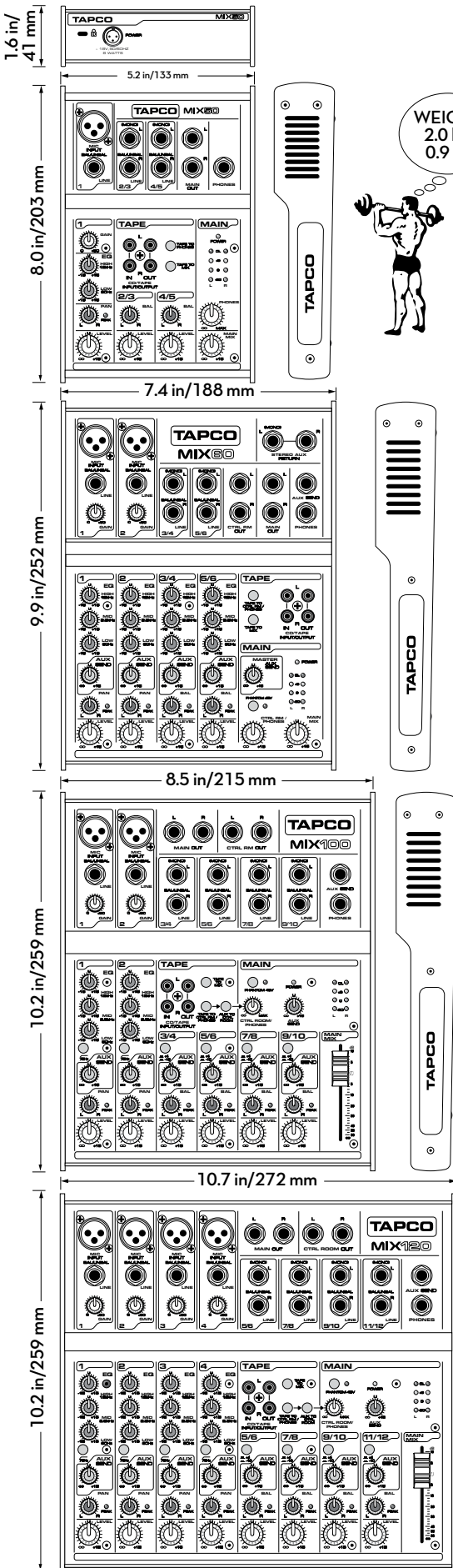

# Block Diagram Mix.50

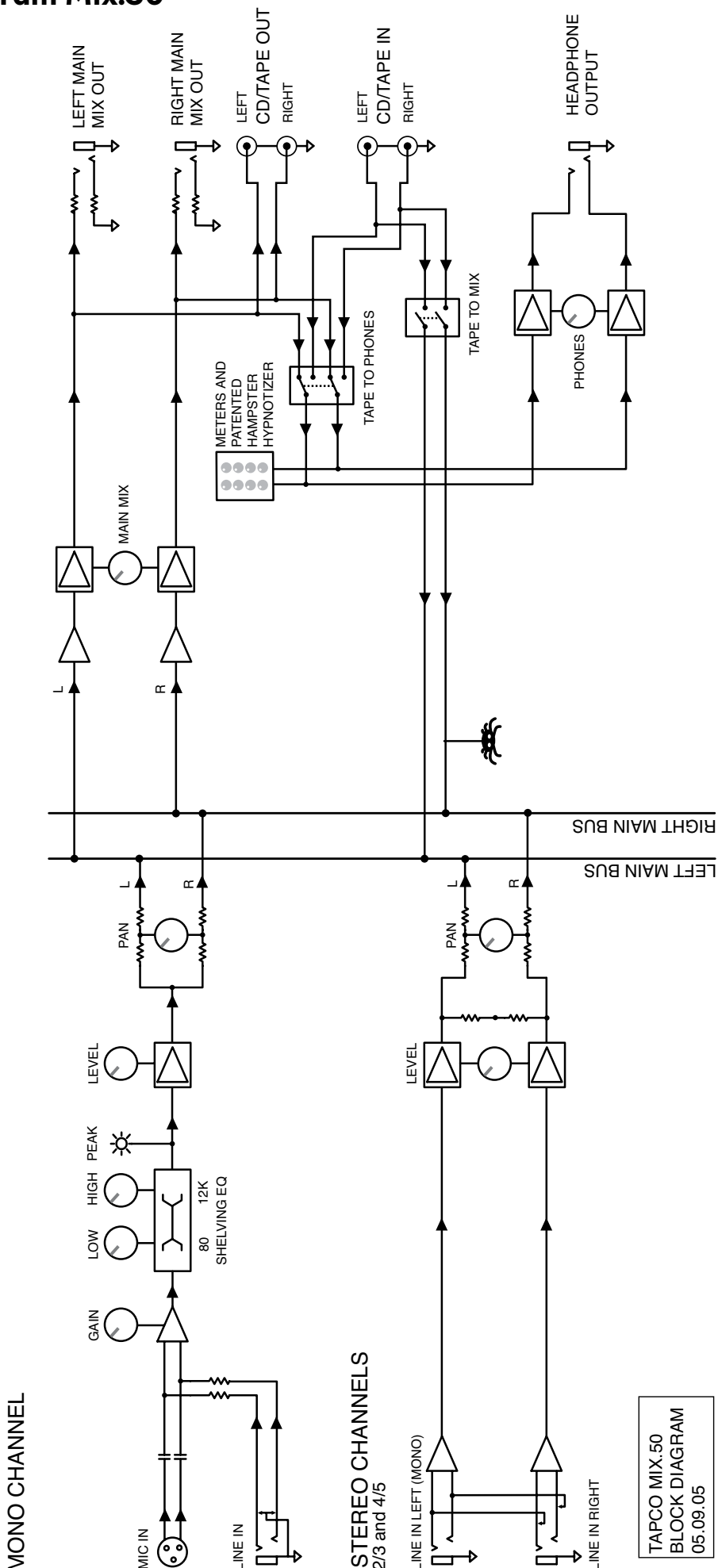

TAPCO MIX.50  
BLOCK DIAGRAM  
05.09.05

# Block Diagram Mix.60

## MONO CHANNELS 1 and 2

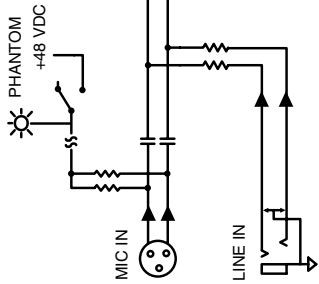

## STEREO CHANNELS 3/4 and 5/6

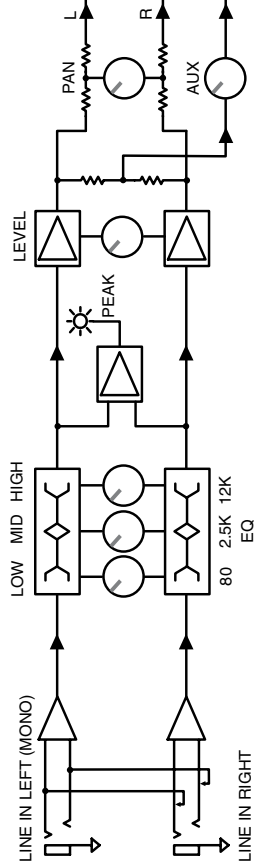

## AUX RETURNS AUX RETURN LEFT (MONO)

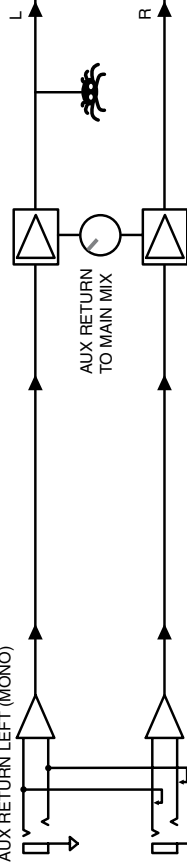

## AUX RETURN RIGHT

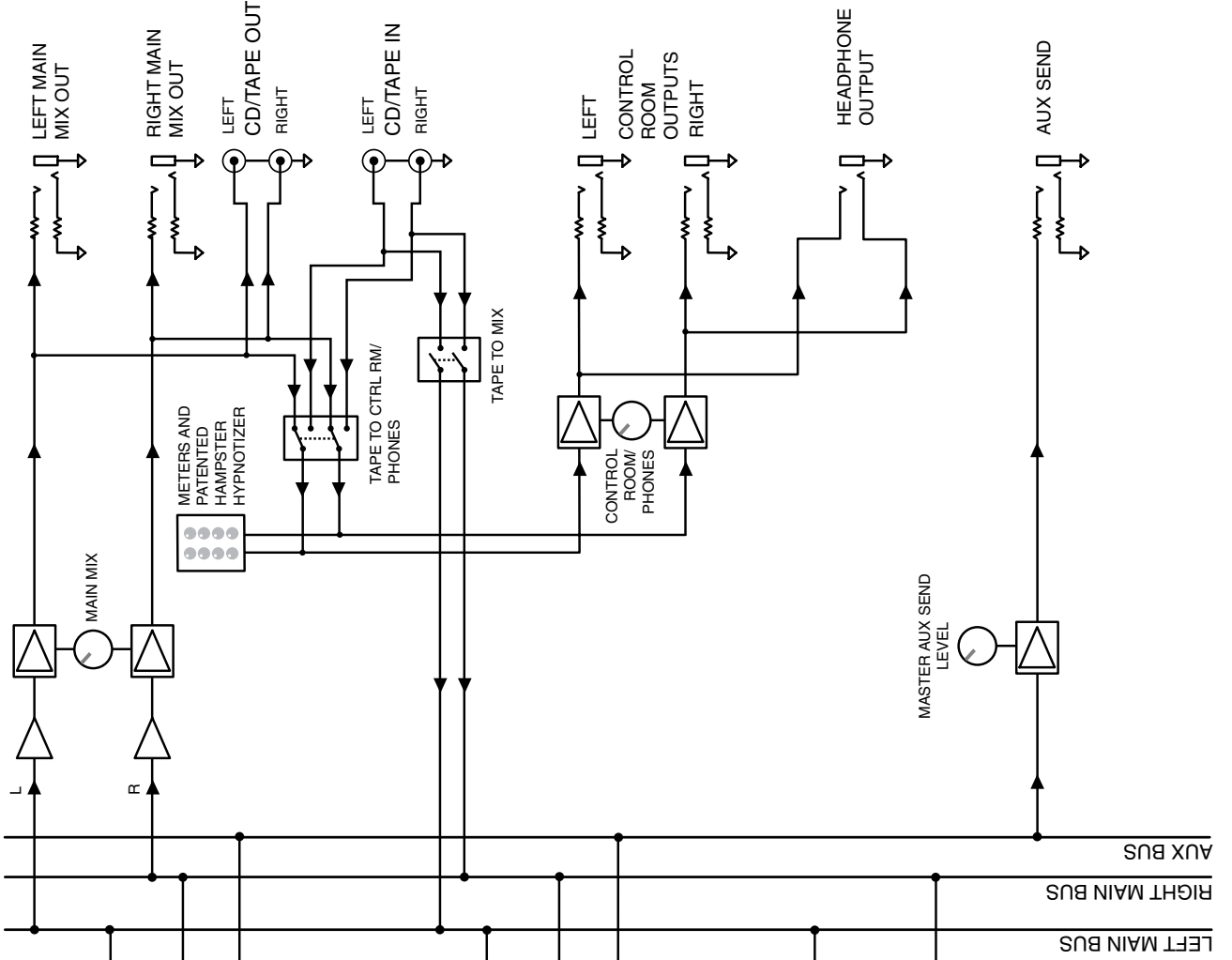

# Block Diagram Mix.100

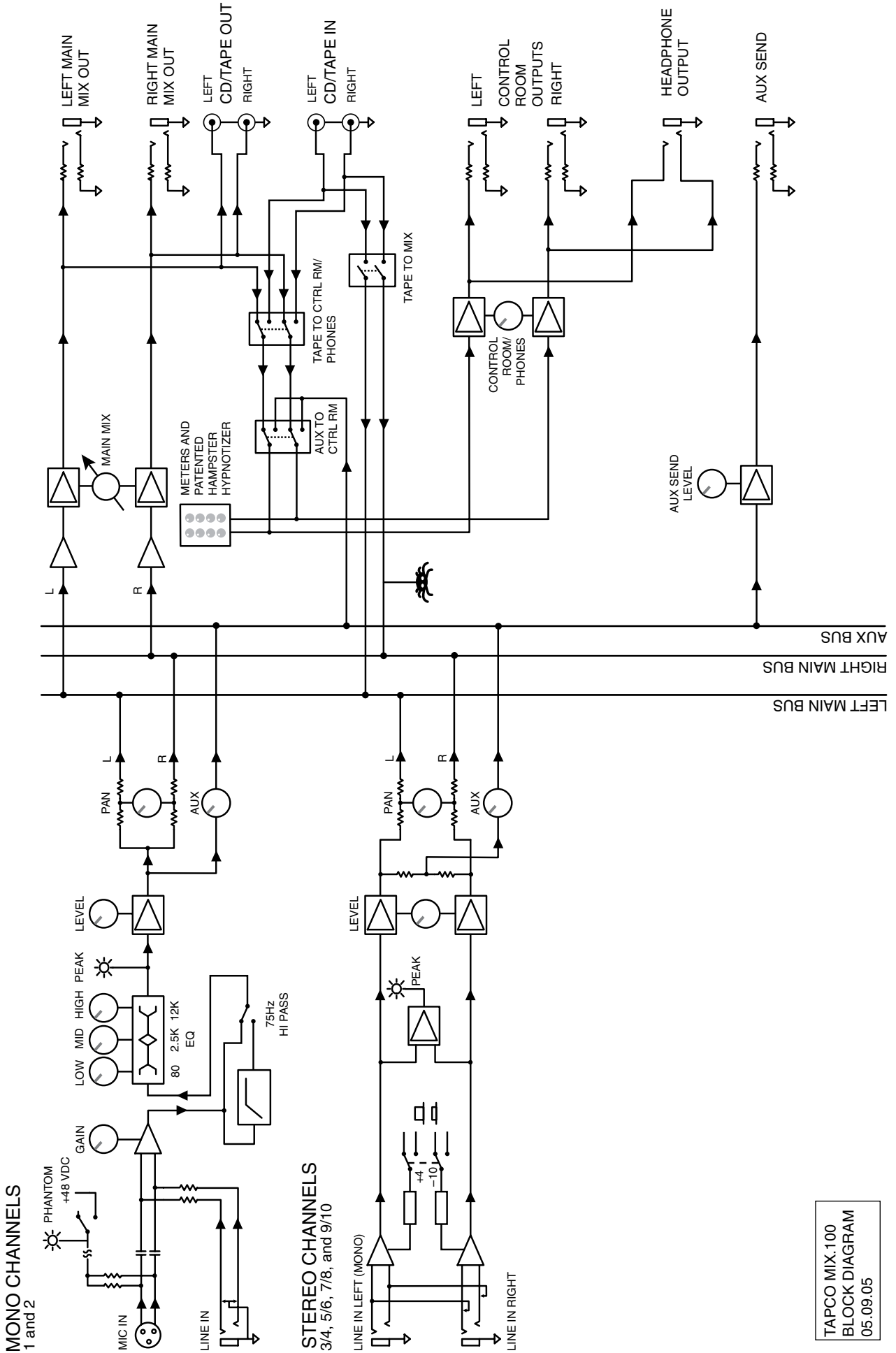

TAPCO MIX.100  
BLOCK DIAGRAM  
05.09.05

# Block Diagram Mix.120

## MONO CHANNELS 1 through 4

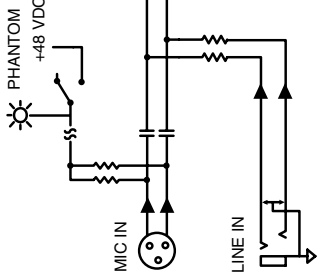

## STEREO CHANNELS 5/6, 7/8, 9/10, and 11/12

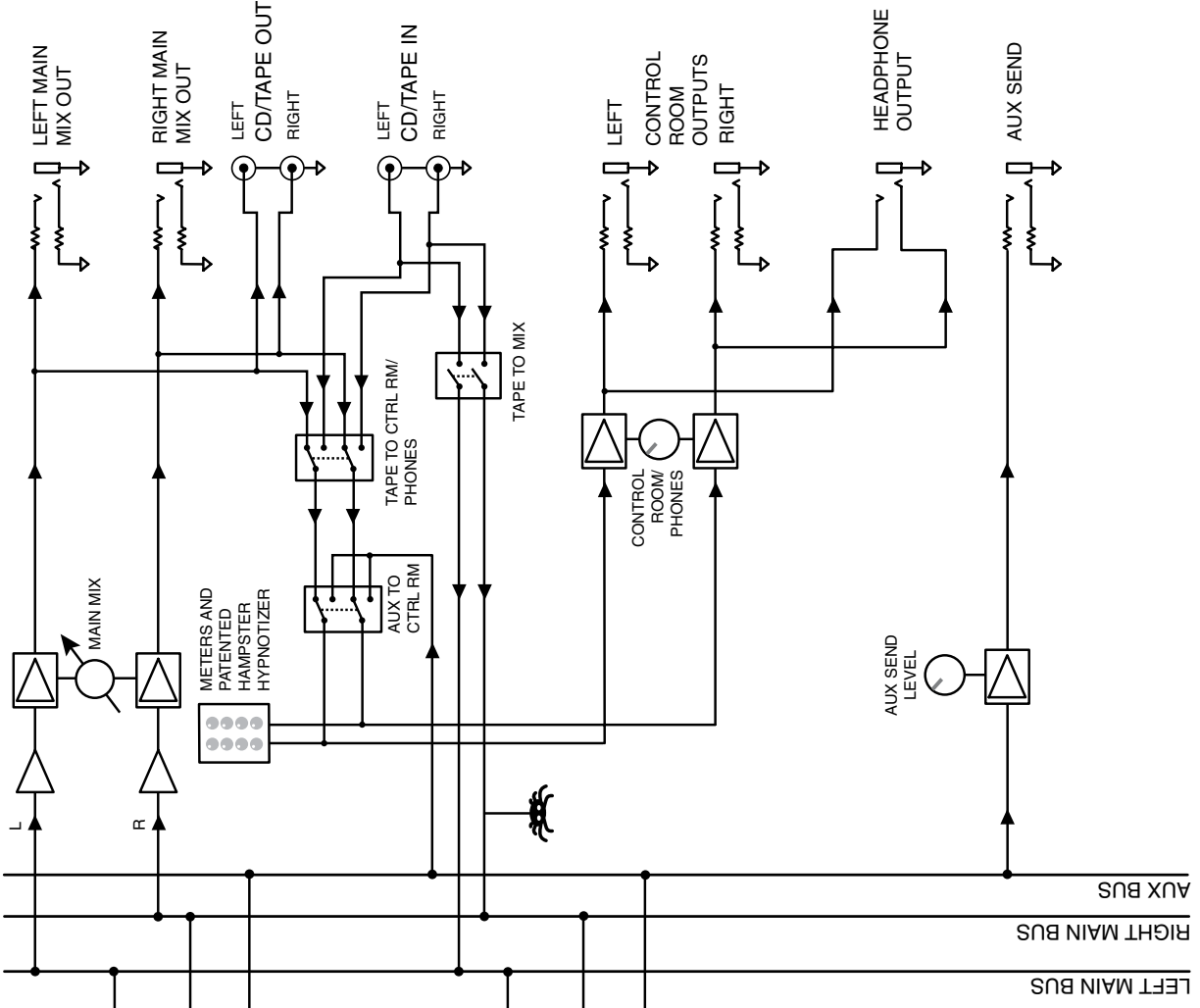
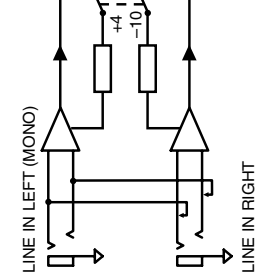

TAPCO MIX.120  
BLOCK DIAGRAM  
05.09.05

# TAPCO LIMITED WARRANTY

- A. LOUD Technologies Inc. warrants all materials, workmanship and proper operation of this product for a period of one year from the original date of purchase. You may purchase an additional 24-month Extended Warranty (for a total of 36 months of coverage). Visit our website and follow the "Register It" links for details ([www.tapcoworld.com](http://www.tapcoworld.com)). If any defects are found in the materials or workmanship or if the product fails to function properly during the applicable warranty period, LOUD Technologies, at its option, will repair or replace the product. This warranty applies only to equipment sold and delivered within the U.S. and Canada by LOUD Technologies Inc. or its authorized dealers.
- B. For faster processing (not to mention a free gift), register online or mail in the product registration card.
- C. Unauthorized service, repairs, or modification of TAPCO products will void this warranty. To obtain repairs or replacement under warranty, you must have a copy of your sales receipt from the authorized TAPCO dealer where you purchased the product. It is necessary to establish purchase date and determine whether your TAPCO product is within the warranty period.
- D. To obtain warranty repair or replacement:
1. Call TAPCO Technical Support at 877/827-2669, 7 AM to 5 PM Monday through Friday (Pacific Time) to get authorization for repair or replacement. Alternately, go to the TAPCO website, click "Talk To Us," and follow the instructions for reporting a warranty issue and submitting a request for an advance replacement.

**2. Advance Replacement:** TAPCO will ship a replacement unit to you along with an invoice for the suggested retail price of the replacement unit. You must return the defective unit immediately to cancel the invoice. If you do not return the defective unit within 30 days, you must pay the full amount stated in the invoice to satisfy your debt.

**3. Repair:** When you call TAPCO Technical Support, explain the problem and obtain a Service Request Number. Have your TAPCO product's serial number ready. **You must have a Service Request Number before you can obtain factory-authorized service.**

- Pack the product in its original shipping carton. Also include a note explaining exactly how to duplicate the problem, a copy of the sales receipt with price and date showing, your daytime phone number and return street address (no P.O. boxes or route numbers, please!), and the Service Request Number. If we cannot duplicate the problem or establish the starting date of your Limited Warranty, we may, at our option, charge for service time and parts.
- Ship the product in its original shipping carton, **freight prepaid** to the authorized service center. Write the Service Request Number in **BIG PRINT** on top of the box. The address of your closest authorized service center will be given to you by Technical Support, or it may be obtained from our website. Once it's repaired, the authorized service center will ship it back by ground shipping, pre-paid (if it qualified as a warranty repair).

**Note:** Under the terms of the warranty, you must ship or drop-off the unit to an authorized service center. The return ground shipment is covered for those units deemed by us to be under warranty.

**Note:** You must have a sales receipt from an authorized TAPCO dealer for your unit to be considered for warranty repair.

**IMPORTANT: Make sure that the Service Request Number is plainly written on the shipping carton. No receipt, no warranty service.**

- E. LOUD Technologies reserves the right to inspect any products that may be the subject of any warranty claims before repair or replacement is carried out. LOUD Technologies may, at our option, require proof of the original date of purchase in the form of a dated copy of the original dealer's invoice or sales receipt. Final determination of warranty coverage lies solely with LOUD Technologies.
- F. Any products returned to one of the LOUD Technologies factory-authorized service centers, and deemed eligible for repair or replacement under the terms of this warranty will be repaired or replaced. LOUD Technologies and its authorized service centers may use refurbished parts for repair or replacement of any product. Products returned to LOUD Technologies that do not meet the terms of this Warranty will not be repaired unless payment is received for labor, materials, return freight, and insurance. Products repaired under warranty will be returned freight prepaid by LOUD Technologies to any location within the boundaries of the USA or Canada.
- G. LOUD Technologies warrants all repairs performed for 90 days or for the remainder of the warranty period. This warranty does not extend to damage resulting from improper installation, misuse, neglect or abuse, or to exterior appearance. This warranty is recognized only if the inspection seals and serial number on the unit have not been defaced or removed.
- H. LOUD Technologies assumes no responsibility for the timeliness of repairs performed by an authorized service center.
- I. This warranty is extended to the original purchaser. This warranty may be transferred to anyone who may subsequently purchase this product within the applicable warranty period for a nominal fee (extended warranties are not transferable). A copy of the original sales receipt is required to obtain warranty repairs or replacement.
- J. This is your sole warranty. LOUD Technologies does not authorize any third party, including any dealer or sales representative, to assume any liability on behalf of LOUD Technologies or to make any warranty for LOUD Technologies Inc.
- K. THE WARRANTY GIVEN ON THIS PAGE IS THE SOLE WARRANTY GIVEN BY LOUD TECHNOLOGIES INC. AND IS IN LIEU OF ALL OTHER WARRANTIES, EXPRESS AND IMPLIED, INCLUDING THE WARRANTIES OF MERCHANTABILITY AND FITNESS FOR A PARTICULAR PURPOSE. THE WARRANTY GIVEN ON THIS PAGE SHALL BE STRICTLY LIMITED IN DURATION TO ONE YEAR FROM THE DATE OF ORIGINAL PURCHASE FROM AN AUTHORIZED TAPCO DEALER. UPON EXPIRATION OF THE APPLICABLE WARRANTY PERIOD, LOUD TECHNOLOGIES INC. SHALL HAVE NO FURTHER WARRANTY OBLIGATION OF ANY KIND. LOUD TECHNOLOGIES INC. SHALL NOT BE LIABLE FOR ANY INCIDENTAL, SPECIAL, OR CONSEQUENTIAL DAMAGES THAT MAY RESULT FROM ANY DEFECT IN THE TAPCO PRODUCT OR ANY WARRANTY CLAIM. Some states do not allow exclusion or limitation of incidental, special, or consequential damages or a limitation on how long warranties last, so some of the above limitations and exclusions may not apply to you. This warranty provides specific legal rights and you may have other rights, which vary from state to state.

**Please keep your sales receipt in a safe place.**



••• tapcoworld.com

**TAPCO**<sup>®</sup>

TOTAL AUDIO PRODUCTION